



# NTA IMPLANT

**CONFIDENCE  
IN STABILITY!**

*World Brand*

[WWW.NTAIMPLANT.COM](http://WWW.NTAIMPLANT.COM) [WWW.NTAIMPLANT.COM](http://WWW.NTAIMPLANT.COM) [WWW.NTAIMPLANT.COM](http://WWW.NTAIMPLANT.COM)

“TO IMPROVE IS TO CHANGE;  
TO BE PERFECT IS TO CHANGE OFTEN”  
WINSTON CHURCHILL



## Precision You Can Trust.

Sterile • Precision Engineered • Clinical Reliability



 **High Predictability Performance**  
Provides stability and control during  
the placement process.

 **Proven Clinical Performance**  
Supports sterile handling and  
application processes.

*Engineered for predictable clinical outcomes and confident workflows.*



*Designed with  
Precision.  
Applied with  
Confidence.*



# Pilatus Swiss Dental GmbH

Pilatus Swiss Dental GmbH strives for excellence in the realm of implant dentistry, crafting exceptional dental implants of the highest caliber. With an unwavering commitment to innovation and precision, our esteemed company holds sole ownership of all products, encompassing product development, manufacturing processes, strategic marketing, brand establishment, and trademark rights. Employing state-of-the-art technologies and drawing insights from cutting-edge scientific research in implantology, our products are thoughtfully engineered to surpass industry standards.

Under the esteemed umbrella of Pilatus Swiss Dental GmbH we proudly present the prestigious brands of NTA Implant, NTA Spure Implant, NTA Shorter Implant, NTA Shorter Plus Implant, and NTA Hybrid Implant. These distinguished labels epitomize our unwavering dedication to crafting two distinguished types of implants, namely the exquisite “Screw-Type” and the illustrious “Press-Fit”, along with their accompanying accessories.

Furthermore, our illustrious company possesses a portfolio of esteemed Quality System Management Certifications, including FDA, MDR 2017/745 Certificate, ISO 9001:2015, ISO 13485:2016, and ISO 10002:2018, testifying to our unwavering commitment to upholding rigorous quality standards.

At Pilatus Swiss Dental GmbH, our esteemed mission propels us to unfailingly deliver the most awe-inspiring products, meticulously manufactured to encompass a comprehensive array of dental implant indications, without compromising on the lofty standards of effectiveness, reliability, and patient safety.

Our visionary path is illuminated by a relentless pursuit of scientific breakthroughs, amalgamating the vanguard of research and development to curate a distinguished range of implant systems, synonymous with exceptional quality, openness to innovation, and a judicious pricing policy. By harnessing advanced technologies, we channel our unwavering commitment to swiftly provide bespoke solutions, tailored to meet your specific needs, while ensuring unparalleled reliability and accessibility. Using effective, reliable and safe treatment methods without compromising the highest quality.

OUR VISION is to combine up-to-date developments in research and innovations in science and offer highest quality products to our customers.

“  
CONFIDENCE IN STABILITY  
”



*Pilatus Swiss Dental GmbH*  
*Our Quality Certifications of Management System*

ISO 9001:2015    ISO 13485:2016    ISO 10002:2018    FDA    CE 2292

6 PAGE	13 PAGE	18 PAGE	36 PAGE	40 PAGE
INFORMATION	IMPLANT	ABUTMENT	DIGITAL	SURGICAL KIT

# INTERNAL SUB-MERGED SYSTEM

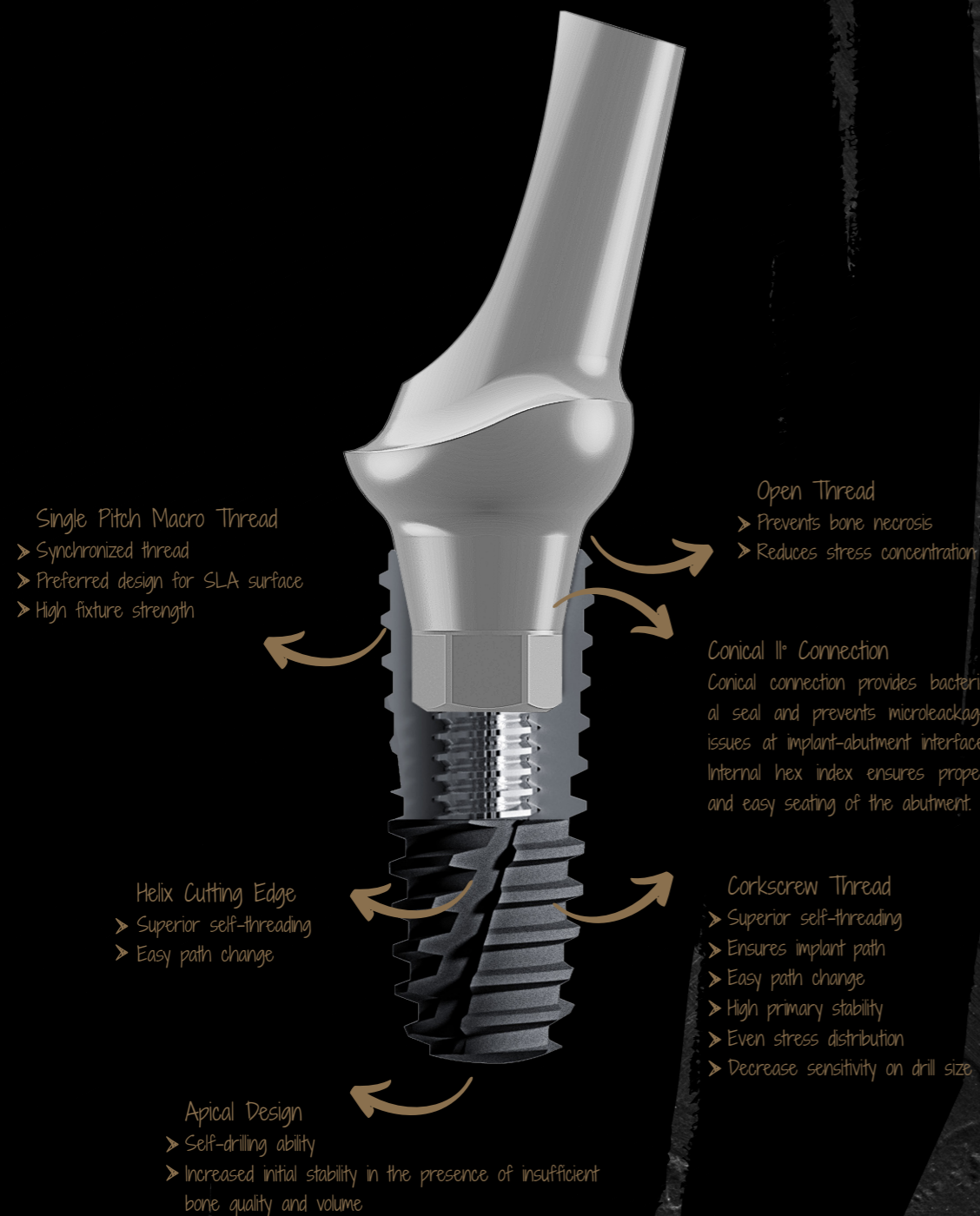

## The Nta Sla Implant Surface

The SLA surface is produced by a large grit sand-blasting process with corundum particles that leads to a macro roughness on the titanium surface. This is followed by a strong acid-etching bath with a HCl at elevated temperature for several minutes. This produces the fine 2-4  $\mu\text{m}$  micro pits superimposed on the rough-blasted surface. The surface is not micro porous and therefore provides no enclosed volumes to reduce vulnerability to bacteria. The chemical composition of the SLA structure was found to be titanium oxide (TiO<sub>2</sub>) using X-ray photoelectron spectroscopy. This method analyses the first few atomic layers of the surface, and thus the chemical composition of the material which is in direct contact and interacts with tissue fluids and cells.

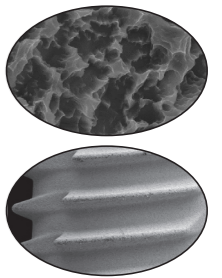

## No-Mount System

Surgery time has been shortened by removing the fixture mount from the package and by using a fixture driver for which the mount is not necessary. However, fixture mouth can be provided separately according to the preference of the clinicians.

## Surgical Drill

Minimize the use of drill extension by making the full length of drill to be 33mm. It can be used conveniently with its 1mm counterbore function in cases where the bone is not flat or when the placement of the implant below the bone level is required.



### Conical Connection With Internal Index

The implant has a conical connection, which provides bacterial seal, eliminates the micromovement and microleakage issues. The bone structure is therefore preserved and abutment screw loosening is prevented. Internal hex index on the other hand, ensures proper and precise seating of the abutment.



### Platform Switching

Implant-abutment junction is placed closer to the center of the implant and away from implant-bone interface. Together with advantages of conical connection, crestal bone lose is a rare phenomenon in NTA implants.

### Flange Cutting

Cutting properties of the threads minimize the trauma caused during implant insertion.

## Cutting Edge

When using the drills that contain three sharp edges, the preparation of the implant osteotomy is easy, the frictional heat formation is low, post-operative pain is limited and the drilling time is quite short.



### Root Form

Root form of the implant ensures easier placement, high initial stability, superior stress distribution, less risk of damaging neighboring roots and low risk for accidental perforation of concave surfaces.



### Non Fixture

If the neck area is exposed, easy cleaning of the area it provided so that the possibility of having perimucositis and periimplantitis is reduced.

NTA COMPLETE GUIDE



NTA PACKING SYSTEM

New Ampoule User's Guide

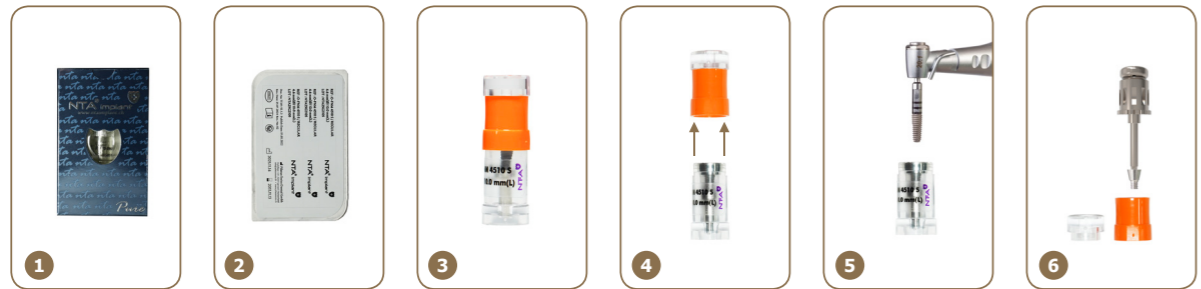

1. Open the package.  
 2. Remove the back of blister (sterility is not guaranteed if the seal is broken).  
 3. Keep the small cover upward.  
 4. Remove the cover by gently rotating and pulling.  
 5. Insert the driver into the fixture and make sure that the driver is fully seated.  
 6. Remove the cover screw from the small chamber using a hex-driver.

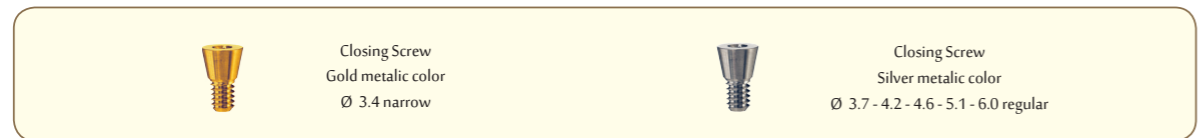

NTA SURGICAL KIT PROTOCOL

BONE	MEDIUM & HARD ( D1 + D2+ D3 )	SOFT ( D+ )	
F I X T U R E	3.4	2.0 + 3.4	2.0 + 2.9
	3.7	2.0 + 3.4 + 3.7	2.0 + 3.4
	4.2	2.0 + 3.4 + 3.7 + 4.2	2.0 + 3.4 + 3.7
	4.6	2.0 + 3.4 + 3.7 + 4.2 + 4.6	2.0 + 3.4 + 3.7 + 4.2
	5.1	2.0 + 3.4 + 3.7 + 4.2 + 4.6 + 5.1	2.0 + 3.4 + 3.7 + 4.2 + 4.6
	6.0	2.0 + 3.4 + 3.7 + 4.2 + 4.6 + 5.1 + 6.0	2.0 + 3.4 + 3.7 + 4.2 + 4.6 + 5.1

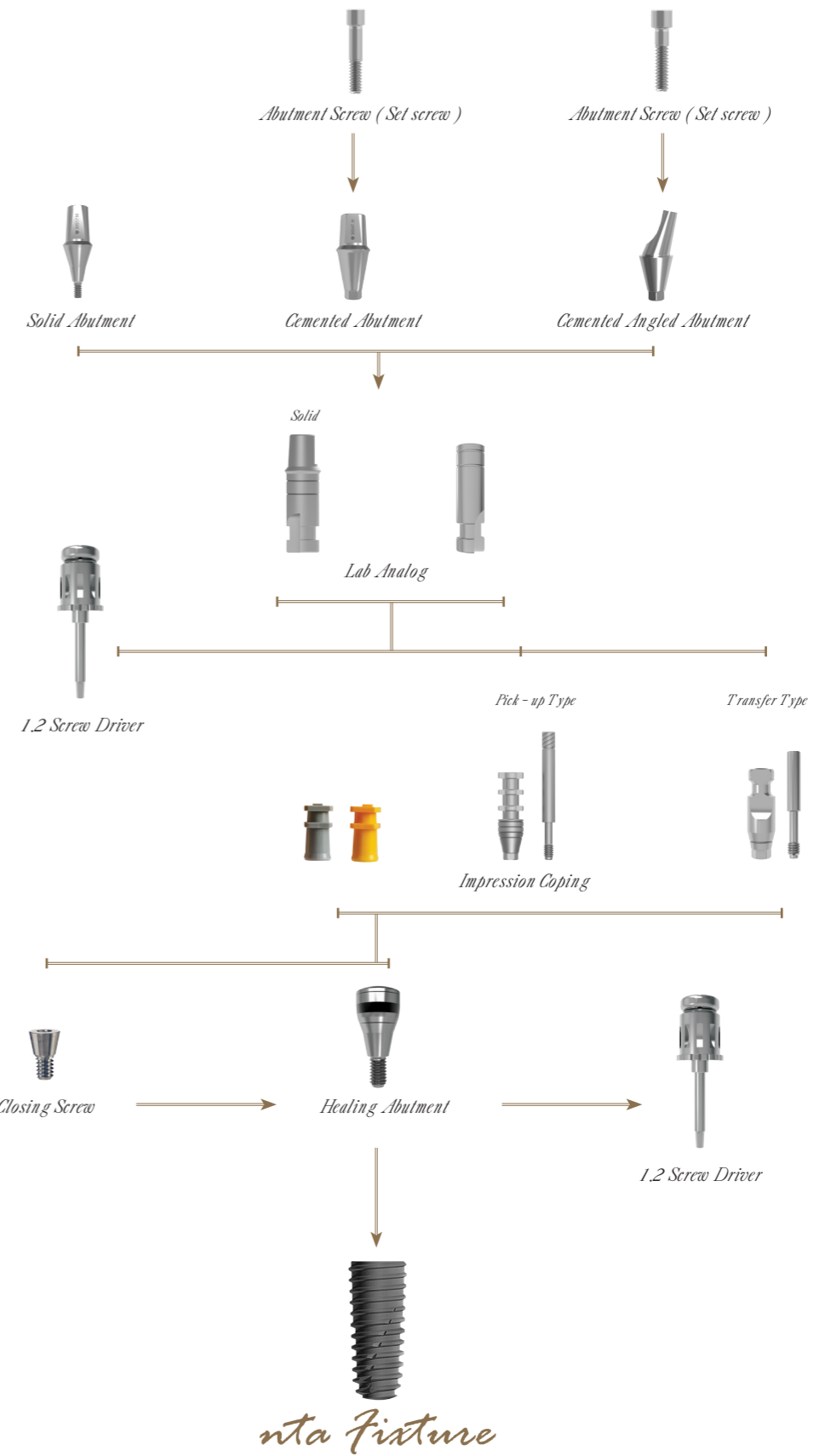

NTA PROSTHETIC FLOW DIAGRAMS FOR OCTA SYSTEM

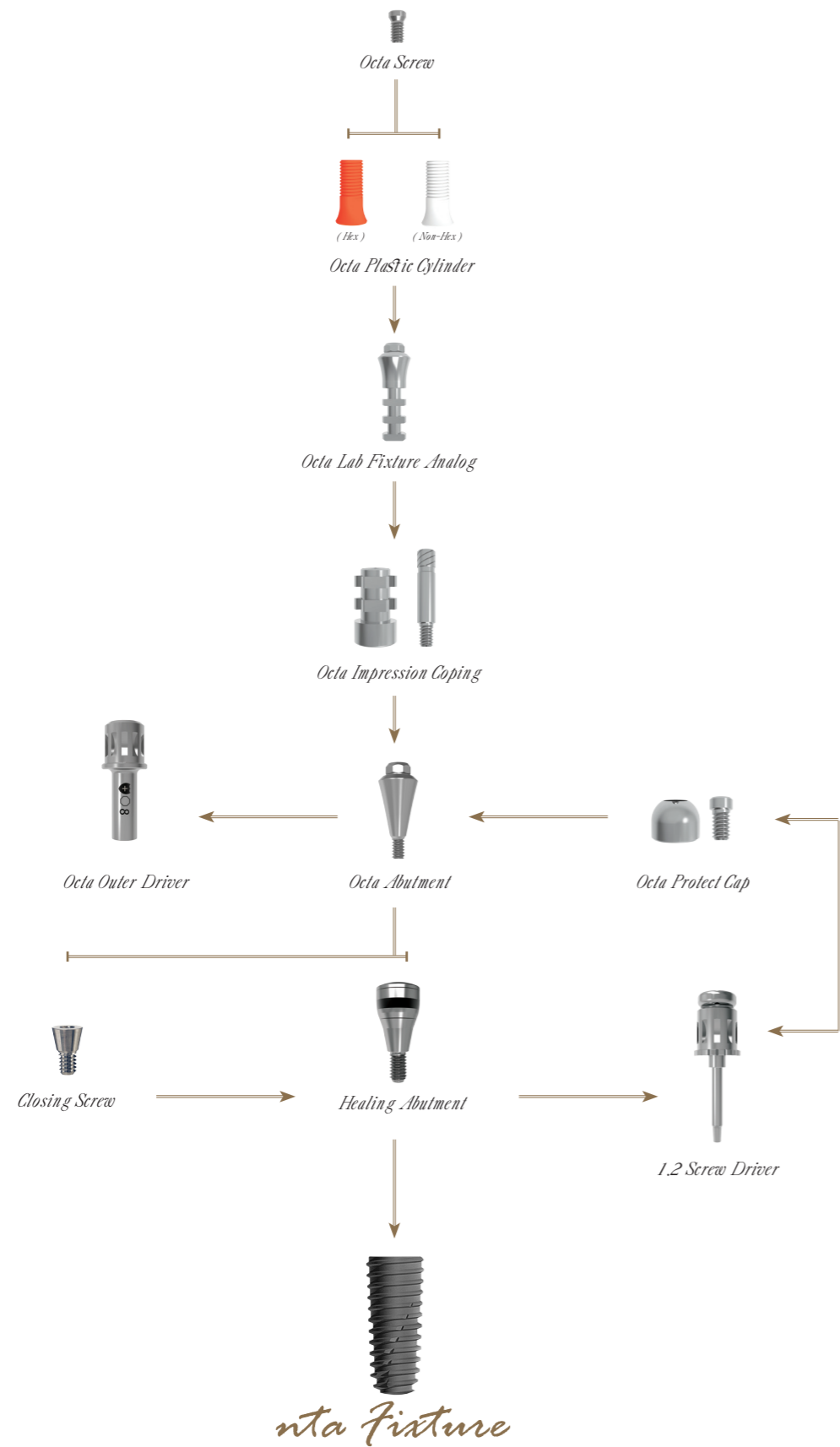

NTA PROSTHETIC FLOW DIAGRAMS FOR MULTI (ALL ON FOUR) SYSTEM

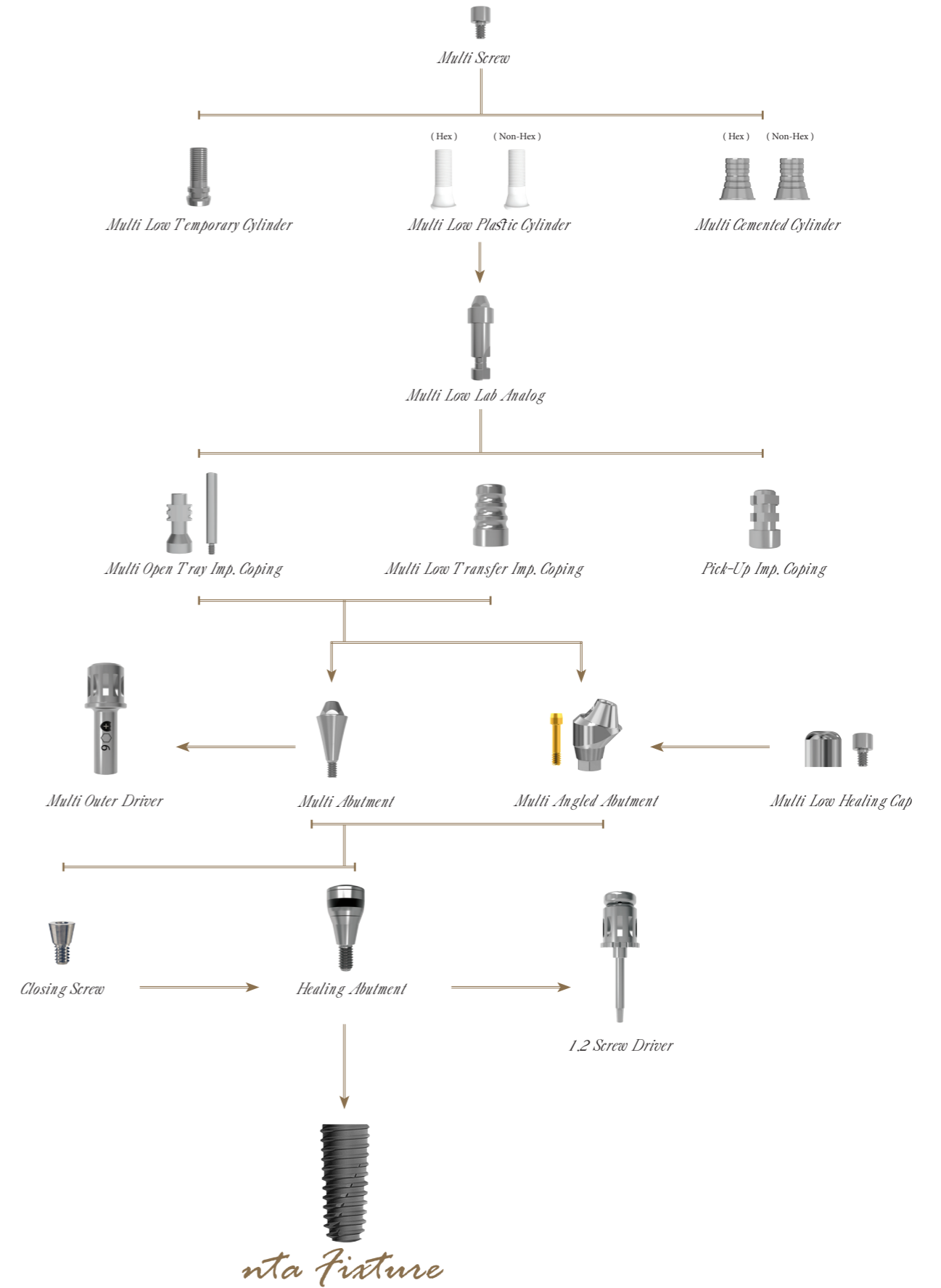

NTA PROSTHETIC FLOW DIAGRAMS FOR NTA SYSTEM  
OVERDENTURE RETAINED RESTORATION : N-LOC

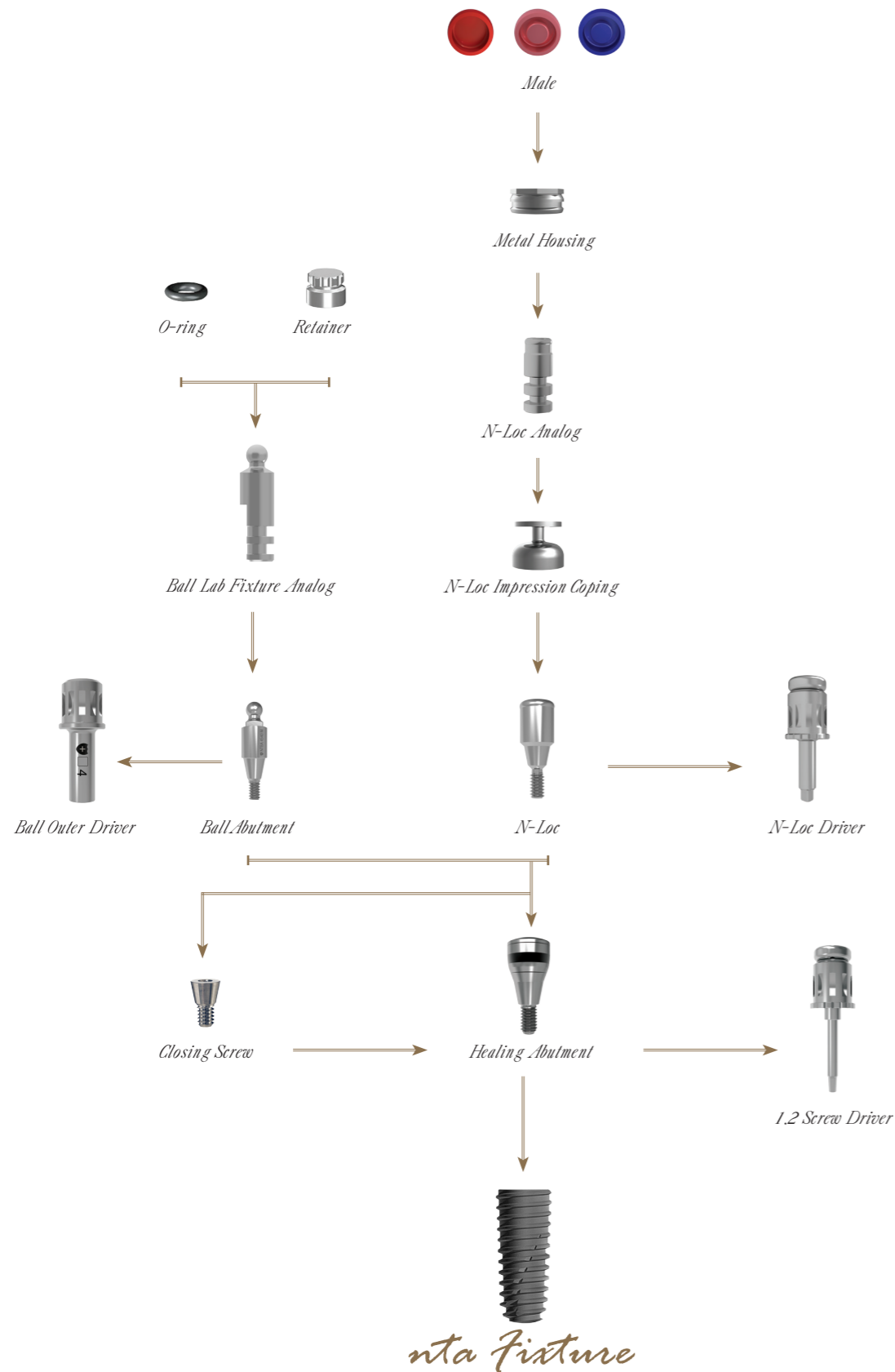

*www.pilatuswiss.ch*



*Premium*  
**STANDARD!...**  
**Digital Excellence in Dentistry!**



**3 SYSTEMS, ONE GOAL IN MIND:**  
*perfection*

## Upper Thread

The implant body is taper thread and this provide spreading stress at the top of the implant. The depth of the threads at the apex part is the highest and its reduce by degrees inside the platform.

The design of the implant enhance blood supply and minimalise the empty place in cortical bone to decrease bone formation period.

## Straight Body

As implant lenght gets longer, the straight body gets longer. For this reason, long implants can be placed steadily without causing unexpectable changes at the time of the surgery same as straight type of implants.

## Narrow

Ø 3.4  
Morse Tapered Connection 11°

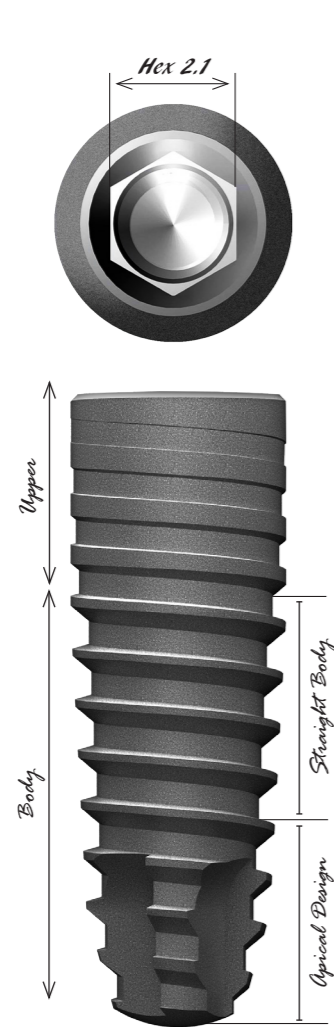

Fixture

Ø 3.4 - Ø 3.7

## Morse Tapered Connection 11°

Implant and abutment excellent connection is waranted. 11° degree morse tapered connection is reducing stress on the fixture and decrease bone loss.

## Open Thread

In the course of implant placement, open thread gives opportunity to place fixture deep without necessity of additional drilling by minimising resistance.

## Cutting Edge

The sharp cutting edge maximized self - tapping.

## Regular

Ø 3.7 - Ø 4.2 - Ø 4.6 - Ø 5.1 - Ø 6.0  
Morse Tapered Connection 11°

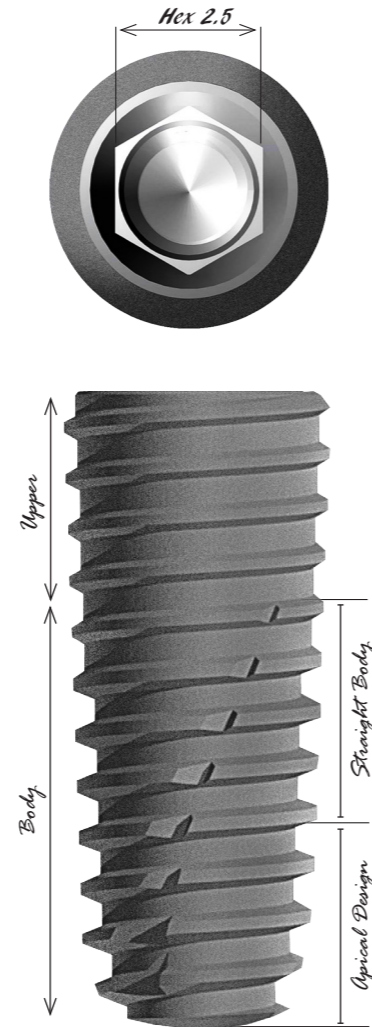

Fixture

Ø 4.2 - Ø 4.6 - Ø 5.1 - Ø 6.0

TF TYPE	Length	Product Code	Screw
Ø 3.4 NARROW 2.1	8.5	O-NTF 3408 S	M 1.6 Abutment Screw
	10	O-NTF 3410 S	
	11.5	O-NTF 3411 S	M 1.6
	13	O-NTF 3413 S	
	15	O-NTF 3415 S	

TF TYPE	Length	Product Code	Screw
Ø 3.7 REGULAR 2.5	7.5	O-NTF 3707 S	M 2.0 Abutment Screw
	8.5	O-NTF 3708 S	
	10	O-NTF 3710 S	
	11.5	O-NTF 3711 S	M 2.0
	13	O-NTF 3713 S	
	15	O-NTF 3715 S	

NM TYPE	Length	Product Code	Screw
Ø 4.2 REGULAR 2.5	7.5	O-FNM 4007 S	M 2.0 Abutment Screw
	8.5	O-FNM 4008 S	
	10	O-FNM 4010 S	
	11.5	O-FNM 4011 S	M 2.0
	13	O-FNM 4013 S	
	15	O-FNM 4015 S	

NM TYPE	Length	Product Code	Screw
Ø 4.6 REGULAR 2.5	6.6	O-FNM 4506 S	M 2.0 Abutment Screw
	7.5	O-FNM 4507 S	
	8.5	O-FNM 4508 S	
	10	O-FNM 4510 S	
	11.5	O-FNM 4511 S	
	13	O-FNM 4513 S	
	15	O-FNM 4515 S	

NM TYPE	Length	Product Code	Screw
Ø 5.1 REGULAR 2.5	6.6	O-FNM 5006 S	M 2.0 Abutment Screw
	7.5	O-FNM 5007 S	
	8.5	O-FNM 5008 S	
	10	O-FNM 5010 S	
	11.5	O-FNM 5011 S	
	13	O-FNM 5013 S	
	15	O-FNM 5015 S	

NM TYPE	Length	Product Code	Screw
Ø 6.0 REGULAR 2.5	6.6	O-FNM 6006 S	M 2.0 Abutment Screw
	7.5	O-FNM 6007 S	
	8.5	O-FNM 6008 S	



No Mount System: Uses a special fixture driver, which is more durable and has easy separation and connection properties.

Surface: SLA  
Recommended Placement Torque: Less than 40Ncm.  
Tapered angle for safer maxillary placement.

### Upper Thread

The implant body is taper thread and this provide spreading stress at the top of the implant. The depth of the threads at the apex part is the highest and its reduce by degrees inside the platform.

The design of the implant enhance blood supply and minimalise the empty place in cortical bone to decrease bone formation period.

### Straight Body

As implant lenght gets longer, the straight body gets longer. For this reason, long implants can be placed steadily without causing unexpectable changes at the time of the surgery same as straight type of implants.

### Morse Tapered Connection 11°

Implant and abutment excellent connection is waranted. 11° degree morse tapered connection is reducing stress on the fixture and decrease bone loss.

### Open Thread

In the course of implant placement, open thread gives opportunity to place fixture deep without necessity of additional drilling by minimising resistance.

### Cutting Edge

The sharp cutting edge maximized self - tapping.

### Narrow

Ø 3.4  
Morse Tapered Connection 11°

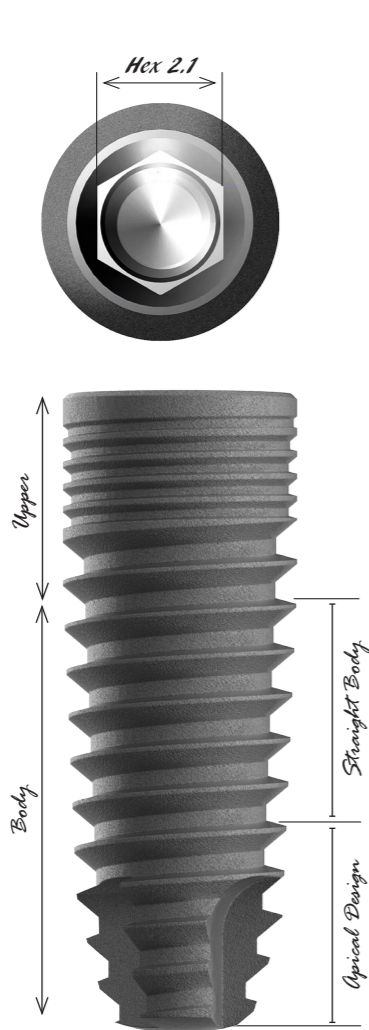

### Regular

Ø 3.7 - Ø 4.2 - Ø 4.6 - Ø 5.1 - Ø 6.0  
Morse Tapered Connection 11°

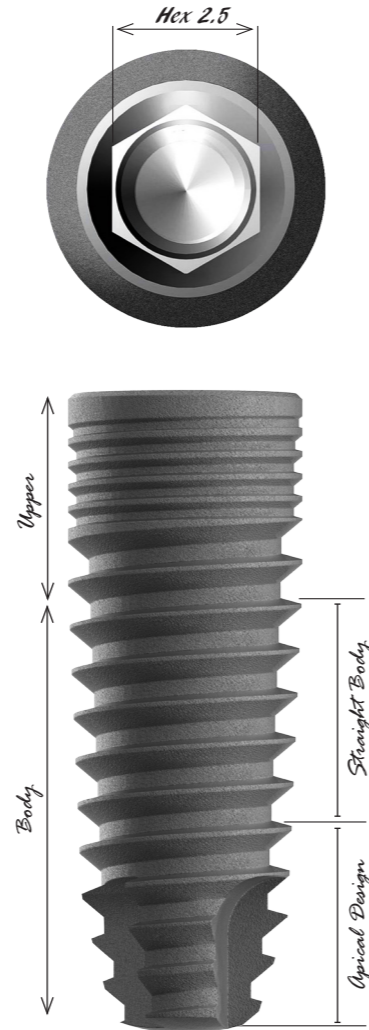

TF TYPE	Length	Product Code	Screw
Ø 3.4 NARROW 2.1	8.5	O-S-NTF 3408 S	M 1.6 Abutment Screw M 1.6
	10	O-S-NTF 3410 S	
	11.5	O-S-NTF 3411 S	
	13	O-S-NTF 3413 S	
	15	O-S-NTF 3415 S	

TF TYPE	Length	Product Code	Screw
Ø 3.7 REGULAR 2.5	7.5	O-S-NTF 3707 S	M 2.0 Abutment Screw M 2.0
	8.5	O-S-NTF 3708 S	
	10	O-S-NTF 3710 S	
	11.5	O-S-NTF 3711 S	
	13	O-S-NTF 3713 S	
15	O-S-NTF 3715 S		

NM TYPE	Length	Product Code	Screw
Ø 4.2 REGULAR 2.5	7.5	O-S-FNM 4007 S	M 2.0 Abutment Screw M 2.0
	8.5	O-S-FNM 4008 S	
	10	O-S-FNM 4010 S	
	11.5	O-S-FNM 4011 S	
	13	O-S-FNM 4013 S	
15	O-S-FNM 4015 S		

NM TYPE	Length	Product Code	Screw
Ø 4.6 REGULAR 2.5	6.6	O-S-FNM 4506 S	M 2.0 Abutment Screw M 2.0
	7.5	O-S-FNM 4507 S	
	8.5	O-S-FNM 4508 S	
	10	O-S-FNM 4510 S	
	11.5	O-S-FNM 4511 S	
	13	O-S-FNM 4513 S	
15	O-S-FNM 4515 S		

NM TYPE	Length	Product Code	Screw
Ø 5.1 REGULAR 2.5	6.6	O-S-FNM 5006 S	M 2.0 Abutment Screw M 2.0
	7.5	O-S-FNM 5007 S	
	8.5	O-S-FNM 5008 S	
	10	O-S-FNM 5010 S	
	11.5	O-S-FNM 5011 S	
	13	O-S-FNM 5013 S	
15	O-S-FNM 5015 S		

NM TYPE	Length	Product Code	Screw
Ø 6.0 REGULAR 2.5	6.6	O-S-FNM 6006 S	M 2.0 Abutment Screw M 2.0
	7.5	O-S-FNM 6007 S	
	8.5	O-S-FNM 6008 S	



No Mount System: Uses a special fixture driver, which is more durable and has easy separation and connection properties.

Surface: Sla  
Recommended Placement Torque: Less than 40Ncm.  
Tapered angle for safer maxillary placement.

NTA® SOFT TISSUE HEALING ABUTMENT

NARROW REGULAR

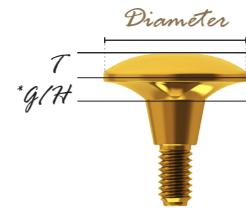

*GBR  
Sinus graft  
Implant stability  
Vertical augmentation  
Immediate implant placement*

Fixture	Diameter	*G/H	Height	Thickness	Product Code
Narrow	Ø 5.5	1	3	1.6	O-STHA 553 M
		3	5		O-STHA 555 M
		5	7		O-STHA 557 M
		7	9		O-STHA 559 M
Regular	Ø 7.2	1	3	1.6	O-STHA 723 T
		3	5		O-STHA 725 T
		5	7		O-STHA 727 T
		7	9		O-STHA 729 T
	Ø 7.6	1	3	1.6	O-STHA 763 T
		3	5		O-STHA 765 T
		5	7		O-STHA 767 T
		7	9		O-STHA 769 T
	Ø 8.1	1	3	1.6	O-STHA 813 T
		3	5		O-STHA 815 T
		5	7		O-STHA 817 T
		7	9		O-STHA 819 T
Ø 9.0	1	3	1.6	O-STHA 903 T	
	3	5		O-STHA 905 T	
	5	7		O-STHA 907 T	
	7	9		O-STHA 909 T	

NTA® HEALING ABUTMENT

NARROW REGULAR

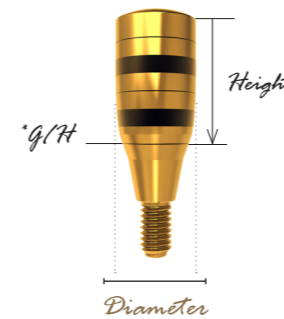
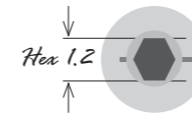

Diameter	*G/H	Height	Product Code
Narrow Ø 4.15	2	3	O-HA 403 M
	3	5	O-HA 405 M
	4	7	O-HA 407 M
	5	9	O-HA 409 M
Narrow Ø 4.5	2	3	O-HA 453 M
	3	5	O-HA 455 M
	4	7	O-HA 457 M
	5	9	O-HA 459 M
Narrow Ø 5.5	2	3	O-HA 553 M
	3	5	O-HA 555 M
	4	7	O-HA 557 M
Regular Ø 4.15	1	2	O-HA 402 S
	2	3	O-HA 403 S
	3	5	O-HA 405 S
	4	7	O-HA 407 S
	5	9	O-HA 409 S
Regular Ø 4.5	1	2	O-HA 452 S
	2	3	O-HA 453 S
	3	5	O-HA 455 S
	4	7	O-HA 457 S
	5	9	O-HA 459 S
Regular Ø 5.5	1	2	O-HA 552 S
	2	3	O-HA 553 S
	3	5	O-HA 555 S
	4	7	O-HA 557 S
	5	9	O-HA 559 S
Regular Ø 6.5	1	2	O-HA 652 S
	2	3	O-HA 653 S
	3	5	O-HA 655 S
	4	7	O-HA 657 S

✓ Hex Driver: 1.2mm.  
✓ Fastening Torque: 5-8Ncm.

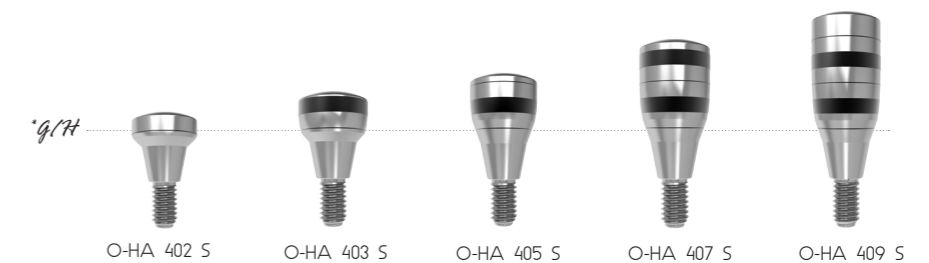

NTA® BONE FORMING HEALING ABUTMENT



Diameter	*G/H	Thickness	Product Code
Ø 5.0	1	0.4	O-BFHA 105
	2		O-BFHA 205
	3	3.0	O-BFHA 335
Ø 6.0	1	0.4	O-BFHA 106
	2		O-BFHA 206
	3	3.0	O-BFHA 336

*Bone Forming Healing Abutment is used for protecting bone graft from tongue and saliva. BF Healing abutment covers bone graft with BF's specific design.*

\*G/H : Gingival Height

**NTA® TEMPORARY ABUTMENT - PLASTIC**

NARROW REGULAR HEX

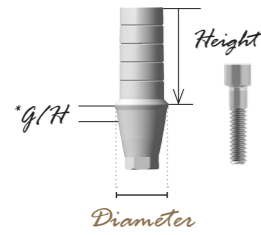

Fixture	Diameter	*G/H	Height	Product Code
Narrow	Ø 4.5	1	8	O-NTTAN 4510 H
		2		O-NTTAN 4520 H
		3		O-NTTAN 4530 H
Regular	Ø 4.5	1	8	O-NTTAR 4510 H
		2		O-NTTAR 4520 H
		3		O-NTTAR 4530 H

**NTA® TEMPORARY ABUTMENT - TITANIUM**

NARROW REGULAR HEX

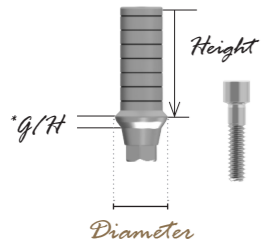

Fixture	Diameter	*G/H	Height	Product Code
Narrow	Ø 4.5	1	10	O-NTTTAN 4510 H
		2		O-NTTTAN 4520 H
		3		O-NTTTAN 4530 H
Regular	Ø 4.5	1	10	O-NTTTAR 4510 H
		2		O-NTTTAR 4520 H
		3		O-NTTTAR 4530 H

**NTA® SOLID ABUTMENT**

NARROW REGULAR

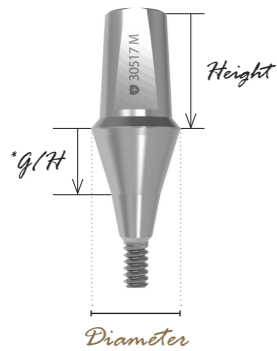
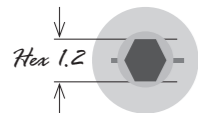

Fixture	Diameter	*G/H	Height	Product Code
Narrow	Ø 4.5	1	4.0	O-NTSA 30514 M
		2		O-NTSA 30524 M
		3		O-NTSA 30534 M
		4		O-NTSA 30544 M
		1	5.5	O-NTSA 30515 M
		2		O-NTSA 30525 M
		3		O-NTSA 30535 M
		4		O-NTSA 30545 M
	1	7.0	O-NTSA 30517 M	
	2		O-NTSA 30527 M	
	3		O-NTSA 30537 M	
	4		O-NTSA 30547 M	
	Ø 5.5	1	7.0	O-NTSA 30617 M
		2		O-NTSA 30627 M
		3		O-NTSA 30637 M
		4		O-NTSA 30647 M

**NTA® SOLID ABUTMENT**

NARROW REGULAR

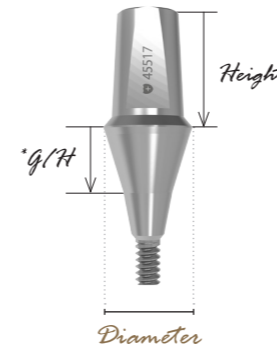
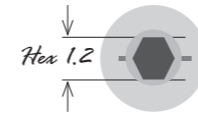

Fixture	Diameter	*G/H	Height	Product Code
Regular	Ø 4.5	1	4.0	O-NTSA 45514
		2		O-NTSA 45524
		3		O-NTSA 45534
		4		O-NTSA 45544
		1	5.5	O-NTSA 45515
		2		O-NTSA 45525
		3		O-NTSA 45535
		4		O-NTSA 45545
		5	O-NTSA 45555	
		6	O-NTSA 45565	
		1	7.0	O-NTSA 45517
		2		O-NTSA 45527
	3	O-NTSA 45537		
	4	O-NTSA 45547		
	Ø 5.5	1	4.0	O-NTSA 55614
		2		O-NTSA 55624
		3		O-NTSA 55634
		4		O-NTSA 55644
		1	5.5	O-NTSA 55615
		2		O-NTSA 55625
		3		O-NTSA 55635
		4		O-NTSA 55645
		5	O-NTSA 55655	
		6	O-NTSA 55665	
1		7.0	O-NTSA 55617	
2			O-NTSA 55627	
3	O-NTSA 55637			
4	O-NTSA 55647			
Ø 6.5	1	4.0	O-NTSA 65714	
	2		O-NTSA 65724	
	3		O-NTSA 65734	
	4		O-NTSA 65744	
	1	5.5	O-NTSA 65715	
	2		O-NTSA 65725	
	3		O-NTSA 65735	
	4		O-NTSA 65745	
	5	O-NTSA 65755		
	6	O-NTSA 65765		
	1	7.0	O-NTSA 65717	
	2		O-NTSA 65727	
3	O-NTSA 65737			

- ✓ An abutment and a set screw, used for fixed prostheses.
- ✓ Hex Driver: 1.2mm.
- ✓ Fastening Torque: 20Ncm (Narrow) - 30Ncm (Regular)
- ✓ Protect Cap: Optional.

NTA® CEMENTED ABUTMENT

NARROW REGULAR HEX

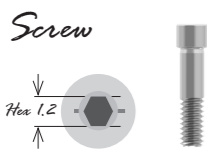
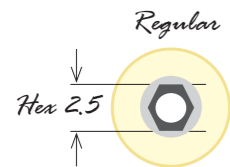
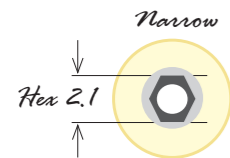
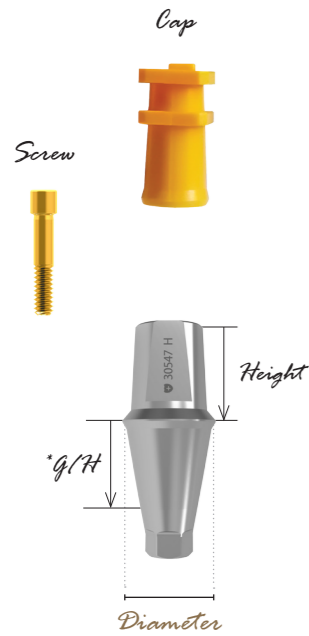

Fixture	Diameter	*G/H	Height	Product Code	Screw		
Narrow	Ø 4.15	1	4.0	O-NTCA 20514 H	M 1.6 O-AAHS 1610		
		2		O-NTCA 20524 H			
		3		O-NTCA 20534 H			
		4		O-NTCA 20544 H			
		1	5.5	O-NTCA 20515 H			
		2		O-NTCA 20525 H			
		3		O-NTCA 20535 H			
		4		O-NTCA 20545 H			
	5	O-NTCA 20555 H					
	6	O-NTCA 20565 H					
	1	7.0	O-NTCA 20517 H				
	2		O-NTCA 20527 H				
	3		O-NTCA 20537 H				
	4		O-NTCA 20547 H				
	Regular	Ø 4.5	1	4.0		O-NTCA 30514 H	M 1.6 O-AAHS 1610
			2			O-NTCA 30524 H	
3			O-NTCA 30534 H				
4			O-NTCA 30544 H				
1			5.5	O-NTCA 30515 H			
2				O-NTCA 30525 H			
3				O-NTCA 30535 H			
4				O-NTCA 30545 H			
5		O-NTCA 30555 H					
6		O-NTCA 30565 H					
1		7.0	O-NTCA 30517 H				
2			O-NTCA 30527 H				
3			O-NTCA 30537 H				
4			O-NTCA 30547 H				
Regular		Ø 4.15	1	4.0	O-NTCA 40514 H	M 2.0 O-AAHS 2010	
			2		O-NTCA 40524 H		
	3		O-NTCA 40534 H				
	4		O-NTCA 40544 H				
	1		5.5	O-NTCA 40515 H			
	2			O-NTCA 40525 H			
	3			O-NTCA 40535 H			
	4			O-NTCA 40545 H			
	5	O-NTCA 40555 H					
	6	O-NTCA 40565 H					
	1	7.0	O-NTCA 40517 H				
	2		O-NTCA 40527 H				
	3		O-NTCA 40537 H				
	4		O-NTCA 40547 H				

- ✓ Abutment for both single unit prosthesis and multi unit fixed partial restorations.
- ✓ Hex Driver: 1.2mm.
- ✓ Fastening Torque: 20Ncm (Narrow) - 30Ncm (Regular)
- ✓ Protect Cap: Optional.

NTA® CEMENTED ABUTMENT

NARROW REGULAR HEX

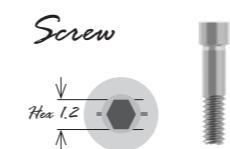
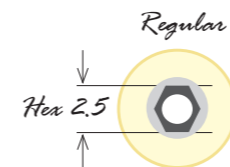
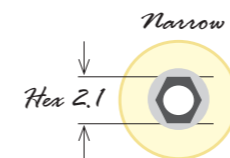
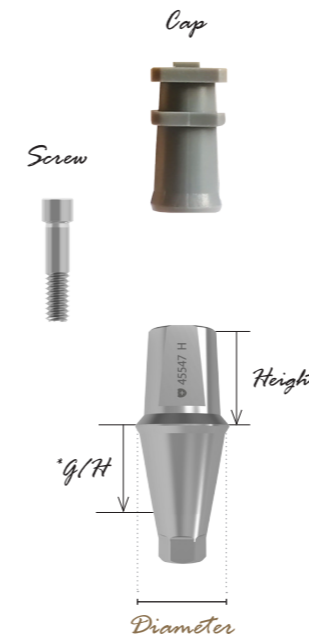

Fixture	Diameter	*G/H	Height	Product Code	Screw		
Regular	Ø 4.5	1	4.0	O-NTCA 45514 H	M 2.0 O-AAHS 2010		
		2		O-NTCA 45524 H			
		3		O-NTCA 45534 H			
		4		O-NTCA 45544 H			
		1	5.5	O-NTCA 45515 H			
		2		O-NTCA 45525 H			
		3		O-NTCA 45535 H			
		4		O-NTCA 45545 H			
	5	O-NTCA 45555 H					
	6	O-NTCA 45565 H					
	1	7.0	O-NTCA 45517 H				
	2		O-NTCA 45527 H				
	3		O-NTCA 45537 H				
	4		O-NTCA 45547 H				
	Regular	Ø 5.5	1	4.0		O-NTCA 55614 H	M 2.0 O-AAHS 2010
			2			O-NTCA 55624 H	
3			O-NTCA 55634 H				
4			O-NTCA 55644 H				
1			5.5	O-NTCA 55615 H			
2				O-NTCA 55625 H			
3				O-NTCA 55635 H			
4				O-NTCA 55645 H			
5		O-NTCA 55655 H					
6		O-NTCA 55665 H					
1		7.0	O-NTCA 55617 H				
2			O-NTCA 55627 H				
3			O-NTCA 55637 H				
4			O-NTCA 55647 H				
Regular		Ø 6.5	1	4.0	O-NTCA 65714 H	M 2.0 O-AAHS 2010	
			2		O-NTCA 65724 H		
	3		O-NTCA 65734 H				
	4		O-NTCA 65744 H				
	1		5.5	O-NTCA 65715 H			
	2			O-NTCA 65725 H			
	3			O-NTCA 65735 H			
	4			O-NTCA 65745 H			
	5	O-NTCA 65755 H					
	6	O-NTCA 65765 H					
	1	7.0	O-NTCA 65717 H				
	2		O-NTCA 65727 H				
	3		O-NTCA 65737 H				
	4		O-NTCA 65747 H				

- ✓ Abutment for both single unit prosthesis and multi unit fixed partial restorations.
- ✓ Hex Driver: 1.2mm.
- ✓ Fastening Torque: 20Ncm (Narrow) - 30Ncm (Regular)
- ✓ Protect Cap: Optional.

NTA® CEMENTED ABUTMENT

REGULAR NON-HEX

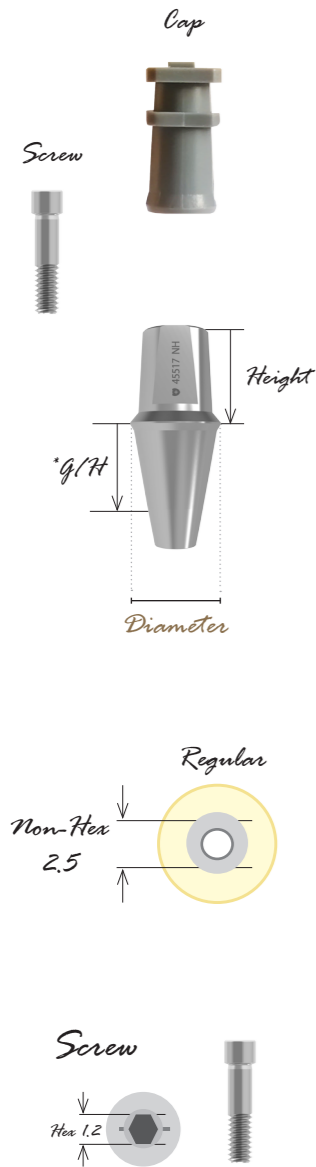

Fixture	Diameter	*G/H	Height	Product Code	Screw		
Regular	Ø 4.5	1	4.0	O-NTCA 45514 NH	M 2.0 O-AAHS 2010		
		2		O-NTCA 45524 NH			
		3		O-NTCA 45534 NH			
		4		O-NTCA 45544 NH			
		1	5.5	O-NTCA 45515 NH			
		2		O-NTCA 45525 NH			
		3		O-NTCA 45535 NH			
		4		O-NTCA 45545 NH			
	5	O-NTCA 45555 NH					
	6	O-NTCA 45565 NH					
	1	7.0	O-NTCA 45517 NH				
	2		O-NTCA 45527 NH				
	3		O-NTCA 45537 NH				
	4		O-NTCA 45547 NH				
	Regular	Ø 5.5	1	4.0		O-NTCA 55614 NH	M 2.0 O-AAHS 2010
			2			O-NTCA 55624 NH	
3			O-NTCA 55634 NH				
4			O-NTCA 55644 NH				
1			5.5	O-NTCA 55615 NH			
2				O-NTCA 55625 NH			
3				O-NTCA 55635 NH			
4				O-NTCA 55645 NH			
5		O-NTCA 55655 NH					
6		O-NTCA 55665 NH					
1		7.0	O-NTCA 55617 NH				
2			O-NTCA 55627 NH				
3			O-NTCA 55637 NH				
4			O-NTCA 55647 NH				
Regular		Ø 6.5	1	4.0	O-NTCA 65714 NH	M 2.0 O-AAHS 2010	
			2		O-NTCA 65724 NH		
	3		O-NTCA 65734 NH				
	4		O-NTCA 65744 NH				
	1		5.5	O-NTCA 65715 NH			
	2			O-NTCA 65725 NH			
	3			O-NTCA 65735 NH			
	4			O-NTCA 65745 NH			
	5	O-NTCA 65755 NH					
	6	O-NTCA 65765 NH					
	1	7.0	O-NTCA 65717 NH				
	2		O-NTCA 65727 NH				
	3		O-NTCA 65737 NH				
	4		O-NTCA 65747 NH				

- ✓ Abutment for both single unit prosthesis and multi unit fixed partial restorations.
- ✓ Hex Driver: 1.2mm.
- ✓ Fastening Torque: 20Ncm (Narrow) - 30Ncm (Regular)
- ✓ Protect Cap: Optional.

NTA® CEMENTED ANGLED ABUTMENT

NARROW REGULAR HEX

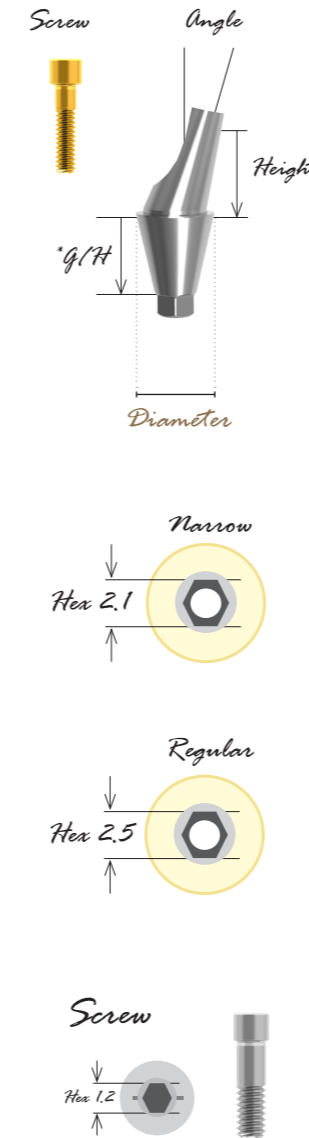

- ✓ Fastening Torque: 20Ncm (Narrow) - 30Ncm (Regular)

Fixture	Diameter	*G/H	Height	Angle	Product Code	Screw
Narrow	Ø 4.5	1	7.0	7°	O-NTAA 45107 MH	M 1.6 O-AAHS 1608A
		2			O-NTAA 45207 MH	
		3			O-NTAA 45307 MH	
		4			O-NTAA 45407 MH	
		1		15°	O-NTAA 45115 MH	
		2			O-NTAA 45215 MH	
		3			O-NTAA 45315 MH	
		4			O-NTAA 45415 MH	
		1		25°	O-NTAA 45125 MH	
		2			O-NTAA 45225 MH	
		3			O-NTAA 45325 MH	
		4			O-NTAA 45425 MH	
	Ø 5.5	7°	1	O-NTAA 55107 MH		
			2	O-NTAA 55207 MH		
			3	O-NTAA 55307 MH		
			4	O-NTAA 55407 MH		
		15°	1	O-NTAA 55115 MH		
			2	O-NTAA 55215 MH		
			3	O-NTAA 55315 MH		
			4	O-NTAA 55415 MH		
25°	1	O-NTAA 55125 MH				
	2	O-NTAA 55225 MH				
	3	O-NTAA 55325 MH				
	4	O-NTAA 55425 MH				
Regular	Ø 5.0	1	7.0	7°	O-NTAA 50107 SH	M 2.0 O-AAHS 2008B
		2			O-NTAA 50207 SH	
		3			O-NTAA 50307 SH	
		4			O-NTAA 50407 SH	
		1		15°	O-NTAA 50115 SH	
		2			O-NTAA 50215 SH	
		3			O-NTAA 50315 SH	
		4			O-NTAA 50415 SH	
		1		25°	O-NTAA 50125 SH	
		2			O-NTAA 50225 SH	
		3			O-NTAA 50325 SH	
		4			O-NTAA 50425 SH	
	Ø 6.0	7°	1	O-NTAA 60107 SH		
			2	O-NTAA 60207 SH		
			3	O-NTAA 60307 SH		
			4	O-NTAA 60407 SH		
		15°	1	O-NTAA 60115 SH		
			2	O-NTAA 60215 SH		
			3	O-NTAA 60315 SH		
			4	O-NTAA 60415 SH		
25°	1	O-NTAA 60125 SH				
	2	O-NTAA 60225 SH				
	3	O-NTAA 60325 SH				
	4	O-NTAA 60425 SH				

**NTA® CEMENTED ANGLED ABUTMENT**

REGULAR NON-HEX

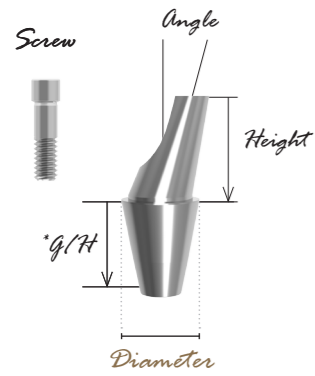

Fixture	Diameter	*G/H	Height	Angle	Product Code	Screw
Regular	Ø 5.0	2	7.0	15°	O-NTAA 50215 NH	M 2.0 O-AAHS 2008B
		4			O-NTAA 50415 NH	
		2		O-NTAA 50225 NH		
		4		O-NTAA 50425 NH		
	Ø 6.0	2	7.0	15°	O-NTAA 60215 NH	
		4			O-NTAA 60415 NH	
		2		O-NTAA 60225 NH		
		4		O-NTAA 60425 NH		

Fastening Torque: 30Ncm (Regular)

**NTA® MILLING ABUTMENT**

NARROW REGULAR HEX NON-HEX



Fixture	Diameter	*G/H	Height	Product Code (Hex)	Product Code (Non-Hex)
Narrow	Ø 4.5	2	12	O-NTMA 452 MH	O-NTMA 452 MNH
Regular	Ø 4.5	2	12	O-NTMA 452 H	O-NTMA 452 NH
		3		O-NTMA 552 H	O-NTMA 552 NH
	Ø 5.5	2		O-NTMA 553 H	O-NTMA 553 NH
		3		O-NTMA 652 H	O-NTMA 652 NH
	Ø 6.5	2		O-NTMA 654 H	O-NTMA 654 NH
		4		O-NTMA 654 H	O-NTMA 654 NH

**NTA® ESTHETIC ABUTMENT**

NARROW REGULAR HEX

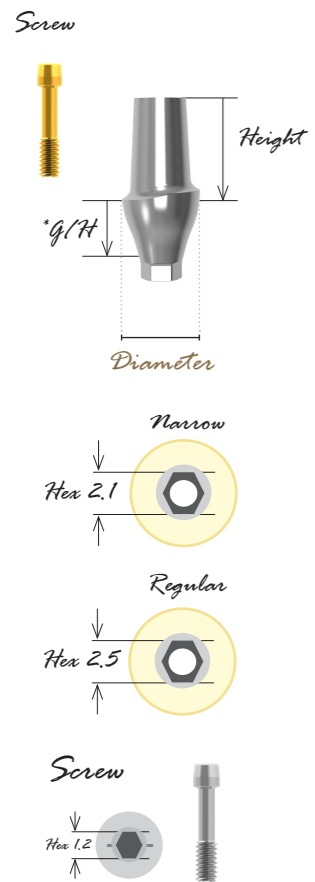

Fixture	Diameter	*G/H	Product Code	Screw
Narrow	Ø 4.0	1.5	O-NTEA 204015	M 1.6 O-EAS 1608
		2	O-NTEA 204020	
		3	O-NTEA 204030	
		4	O-NTEA 204040	
	Ø 4.5	1.5	O-NTEA 204515	
		2	O-NTEA 204520	
		3	O-NTEA 204530	
		4	O-NTEA 204540	
Regular	Ø 4.5	1.5	O-NTEA 504515	M 2.0 O-EAS 2010
		2	O-NTEA 504520	
		3	O-NTEA 504530	
		4	O-NTEA 504540	
	Ø 5.5	1.5	O-NTEA 505515	
		2	O-NTEA 505520	
		3	O-NTEA 505530	
		4	O-NTEA 505540	
	Ø 6.5	1.5	O-NTEA 506515	
		2	O-NTEA 506520	
		3	O-NTEA 506530	
		4	O-NTEA 506540	

Fastening Torque: 20Ncm (Narrow) - 30Ncm (Regular)

**NTA® ESTHETIC ANGLED ABUTMENT**

NARROW REGULAR HEX

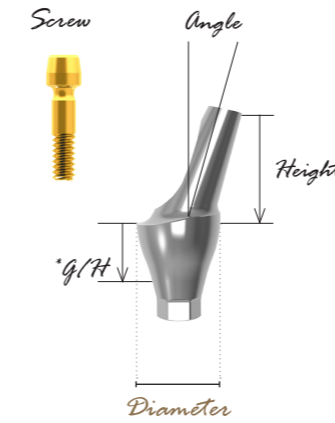

Fixture	Diameter	*G/H	Angle	Product Code	Screw
Narrow	Ø 4.0	1.5	7°	O-NTEA 274015	M 1.6 O-EAS 1608
		2		O-NTEA 274020	
		3		O-NTEA 274030	
		4		O-NTEA 274040	
		17°	1.5	O-NTEA 24015	
			2	O-NTEA 24020	
			3	O-NTEA 24030	
			4	O-NTEA 24040	
	Ø 4.5	7°	1.5	O-NTEA 274515	
			2	O-NTEA 274520	
			3	O-NTEA 274530	
			4	O-NTEA 274540	
		17°	1.5	O-NTEA 24515	
			2	O-NTEA 24520	
			3	O-NTEA 24530	
			4	O-NTEA 24540	
Regular	Ø 4.5	7°	1.5	O-NTEA 574515	M 2.0 O-EAS 2010
			2	O-NTEA 574520	
			3	O-NTEA 574530	
			4	O-NTEA 574540	
		17°	1.5	O-NTEA 54515	
			2	O-NTEA 54520	
			3	O-NTEA 54530	
			4	O-NTEA 54540	
	Ø 5.5	7°	1.5	O-NTEA 575515	
			2	O-NTEA 575520	
			3	O-NTEA 575530	
			4	O-NTEA 575540	
		17°	1.5	O-NTEA 55515	
			2	O-NTEA 55520	
			3	O-NTEA 55530	
			4	O-NTEA 55540	
	Ø 6.5	7°	1.5	O-NTEA 576515	
			2	O-NTEA 576520	
			3	O-NTEA 576530	
			4	O-NTEA 576540	
		17°	1.5	O-NTEA 56515	
			2	O-NTEA 56520	
			3	O-NTEA 56530	
			4	O-NTEA 56540	

Fastening Torque: 20Ncm (Narrow) - 30Ncm (Regular)

*Esthetic Abutments conical connection;  
Prefabricated titanium abutments available in straight and angled;  
and varying collar heights.*

**NTA® UCLA ABUTMENT**

NARROW REGULAR HEX NON-HEX



Fixture	Diameter	Product Code (Hex)	Product Code (Non-Hex)
Narrow	Ø 4.2	O-UCA2107 M	O-UCA2107 MNH
Regular		O-UCA2507	O-UCA2507 NH

**NTA® OCTA ABUTMENT**

NARROW REGULAR

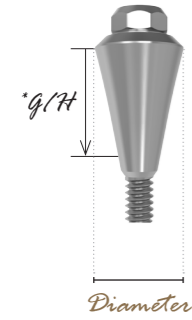

Fixture	Diameter	*G/H	Product Code
Narrow	Ø 4.8	1	O-OAA 481 M
		2	O-OAA 482 M
		3	O-OAA 483 M
		4	O-OAA 484 M
Regular	Ø 4.8	1	O-OAA 481
		2	O-OAA 482
		3	O-OAA 483
		4	O-OAA 484

Fastening Torque: 20Ncm (Narrow) - 30Ncm (Regular)

**Octa Abutment Plastic Cylinder**



Diameter	Product Code
Ø 4.8	O-PO4810 N
Ø 4.8	O-PO4810 H

**Octa Abutment Protect Cap**

Diameter	Height	Product Code
Ø 4.8	4	O-OAPC 4840

- Hex Driver: 1.2mm.
- Fastening Torque: 20Ncm.
- Packing Contents: Healing cap + Cylinder screw.



**Octa Abutment Pick-Up Impression Coping**

Diameter	Height	Product Code
Ø 4.8	10	O-OAIC 4810

- Hex Driver: 1.2mm.
- Minimizes distortion.
- Packing Contents: Impression coping + Guided pin.

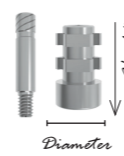

**Octa Abutment Outer Driver**

Height	Product Code
12	O-OAOD



**NTA® MULTI ABUTMENT**

ALL ON FOUR SYSTEM NARROW REGULAR

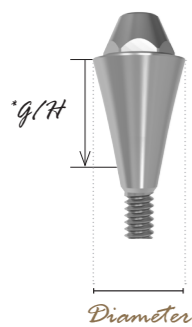

Fixture	Diameter	*G/H	Product Code
Narrow	Ø 4.8	0.5	O-NTMA(N) 5005
		1	O-NTMA(N) 5010
		2	O-NTMA(N) 5020
		3	O-NTMA(N) 5030
Regular	Ø 4.8	0.5	O-NTMA(R) 5005
		1	O-NTMA(R) 5010
		2	O-NTMA(R) 5020
		3	O-NTMA(R) 5030
		4	O-NTMA(R) 5040

Fastening Torque: 20Ncm (Narrow) - 30Ncm (Regular)

**NTA® MULTI ANGLED ABUTMENT**

ALL ON FOUR SYSTEM NARROW REGULAR

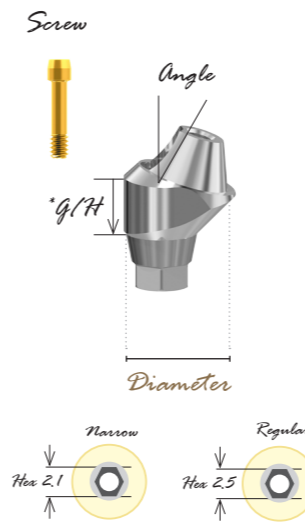

Fixture	Diameter	*G/H	Angle	Product Code	Screw
Narrow	Ø 4.8	2	17°	O-NT17MAN 4820	O-BMANS200
		3		O-NT17MAN 4830	
		4		O-NT17MAN 4840	
		3		O-NT30MAN 4830	
		4		O-NT30MAN 4840	
Regular	Ø 4.8	5	30°	O-NT30MAN 4850	O-BMARS200
		2		O-NT17MAR 4820	
		3		O-NT17MAR 4830	
		4		O-NT17MAR 4840	
		3		O-NT30MAR 4830	
		4	30°	O-NT30MAR 4840	
		5		O-NT30MAR 4850	

Fastening Torque: 20Ncm (Narrow) - 30Ncm (Regular)

\*G/H : Gingival Height

**Multi Low Plastic Cylinder**



Diameter	Height	Product Code
Ø 4.8	12	O-MEPC 4846 H
Ø 4.8	12	O-MEPC 4846 NH

**Multi Low Temporary Cylinder**

Diameter	Height	Product Code
Ø 4.8	12	O-METC 48



**Multi Open Tray Impression Coping**

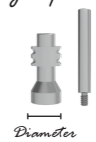

Diameter	Height	Product Code
Ø 4.8	11	O-MEOTIC 4811 H
	11	O-MEOTIC 4811 NH

- Minimizes distortion.
- Packing Contents: Impression coping + Guided pin.

**Multi Low Healing Cap**

Diameter	Height	Product Code
Ø 4.8	4.6	O-MEHC 4880



**Multi Cemented Cylinder**

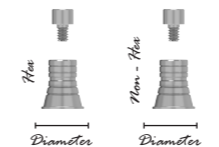

Diameter	Height	Product Code
Ø 5.0	6.0	O-MACC 5060 H
Ø 5.0	6.0	O-MACC 5060 NH

**Multi Low Lab Analog**

Diameter	Height	Product Code
Ø 4.8	15	O-MELA 300



**Multi Outer Driver**

Height	Product Code
12	O-MAOD



**Multi Pick-Up Impression Coping**

Diameter	Height	Product Code
Ø 4.8	10	O-MEPC 4810

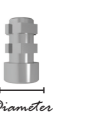

**Multi Low Transfer Impression Coping**

Diameter	Height	Product Code
Ø 4.8	8.0	O-METIC 4880



**Multi Profile Drill**

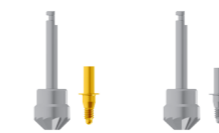

Abutment	Product Code
Narrow	O-NTA-0-65-01
Regular	O-NTA-0-65-02

Easy Use, Strong Connection!  
**FULLY DIGITAL**  
**NO BREAKAGE / LOOSENING**  
**EASY TO TORQUE**  
**CAN BE APPLIED DIRECTLY TO MUA**

Diameter	Height	Product Code
Ø 2.2	4.7	O-NTEZ 2247

**Ez Screw®**



NTA® T-BASE ABUTMENT

NARROW REGULAR HEX

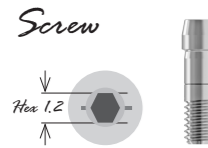
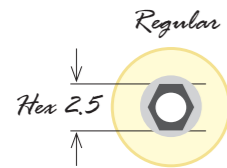
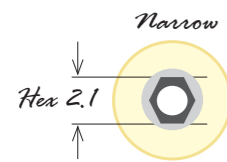
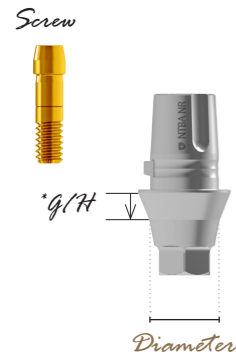

Fixture	Diameter	*G/H	Height	Product Code	Screw	
Narrow	Ø 4.5	1	4.5	O-NTBA NR (4510 H)	M 1.6 O-AAHS 1608A	
		2		O-NTBA NR (4520 H)		
		3		O-NTBA NR (4530 H)		
		4		O-NTBA NR (4540 H)		
		5		O-NTBA NR (4550 H)		
	Ø 5.5	1	4.5	O-NTBA NR (5510 H)		
		2		O-NTBA NR (5520 H)		
		3		O-NTBA NR (5530 H)		
		4		O-NTBA NR (5540 H)		
		5		O-NTBA NR (5550 H)		
	Ø 4.5	5.5	1	O-NTBA NR (554510 H)		
			2	O-NTBA NR (554520 H)		
			3	O-NTBA NR (554530 H)		
			4	O-NTBA NR (554540 H)		
			5	O-NTBA NR (554550 H)		
		6.5	1	O-NTBA NR (555510 H)		
			2	O-NTBA NR (555520 H)		
			3	O-NTBA NR (555530 H)		
			4	O-NTBA NR (555540 H)		
			5	O-NTBA NR (555550 H)		
Ø 5.5	6.5	1	O-NTBA NR (654510 H)			
		2	O-NTBA NR (654520 H)			
		3	O-NTBA NR (654530 H)			
		4	O-NTBA NR (654540 H)			
		5	O-NTBA NR (654550 H)			
	Regular	Ø 4.5	1	4.5	O-NTBA RG (4510 H)	M 2.0 O-TBS 2008
			2		O-NTBA RG (4520 H)	
			3		O-NTBA RG (4530 H)	
			4		O-NTBA RG (4540 H)	
			5		O-NTBA RG (4550 H)	
Ø 5.5		1	4.5	O-NTBA RG (5510 H)		
		2		O-NTBA RG (5520 H)		
		3		O-NTBA RG (5530 H)		
		4		O-NTBA RG (5540 H)		
		5		O-NTBA RG (5550 H)		
Ø 4.5		5.5	1	O-NTBA RG (554510 H)		
			2	O-NTBA RG (554520 H)		
			3	O-NTBA RG (554530 H)		
			4	O-NTBA RG (554540 H)		
			5	O-NTBA RG (554550 H)		
		6.5	1	O-NTBA RG (555510 H)		
			2	O-NTBA RG (555520 H)		
			3	O-NTBA RG (555530 H)		
			4	O-NTBA RG (555540 H)		
			5	O-NTBA RG (555550 H)		
Ø 5.5	6.5	1	O-NTBA RG (654510 H)			
		2	O-NTBA RG (654520 H)			
		3	O-NTBA RG (654530 H)			
		4	O-NTBA RG (654540 H)			
		5	O-NTBA RG (654550 H)			

Fastening Torque: 20Ncm (Narrow) - 30Ncm (Regular)

NTA® T-BASE ABUTMENT

NARROW REGULAR HEX



Fixture	Diameter	*G/H	Height	Product Code	Screw
Regular	Ø 4.5	1	6.5	O-NTBA RG (654510 H)	M 2.0 O-TBS 2008
		2		O-NTBA RG (654520 H)	
		3		O-NTBA RG (654530 H)	
		4		O-NTBA RG (654540 H)	
		5		O-NTBA RG (654550 H)	
	Ø 5.5	1	6.5	O-NTBA RG (655510 H)	
		2		O-NTBA RG (655520 H)	
		3		O-NTBA RG (655530 H)	
		4		O-NTBA RG (655540 H)	
		5		O-NTBA RG (655550 H)	

Fastening Torque: 20Ncm (Narrow) - 30Ncm (Regular)

NTA® T-BASE ABUTMENT

NARROW REGULAR NON-HEX

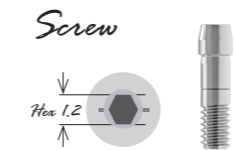
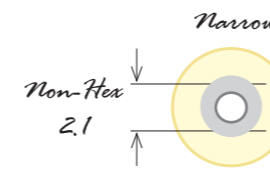

Fixture	Diameter	*G/H	Height	Product Code	Screw
Narrow	Ø 4.5	1	4.5	O-NTBA NR (4510 NH)	M 1.6 O-AAHS 1608A
		2		O-NTBA NR (4520 NH)	
		3		O-NTBA NR (4530 NH)	
		4		O-NTBA NR (4540 NH)	
		5		O-NTBA NR (4550 NH)	
	Ø 5.5	1	4.5	O-NTBA NR (5510 NH)	
		2		O-NTBA NR (5520 NH)	
		3		O-NTBA NR (5530 NH)	
		4		O-NTBA NR (5540 NH)	
		5		O-NTBA NR (5550 NH)	
	Ø 4.5	5.5	1	O-NTBA NR (554510 NH)	
			2	O-NTBA NR (554520 NH)	
			3	O-NTBA NR (554530 NH)	
			4	O-NTBA NR (554540 NH)	
			5	O-NTBA NR (554550 NH)	
		6.5	1	O-NTBA NR (555510 NH)	
			2	O-NTBA NR (555520 NH)	
			3	O-NTBA NR (555530 NH)	
			4	O-NTBA NR (555540 NH)	
			5	O-NTBA NR (555550 NH)	
	Ø 5.5	5.5	1	O-NTBA NR (654510 NH)	
			2	O-NTBA NR (654520 NH)	
			3	O-NTBA NR (654530 NH)	
			4	O-NTBA NR (654540 NH)	
			5	O-NTBA NR (654550 NH)	
		6.5	1	O-NTBA NR (655510 NH)	
			2	O-NTBA NR (655520 NH)	
			3	O-NTBA NR (655530 NH)	
			4	O-NTBA NR (655540 NH)	
			5	O-NTBA NR (655550 NH)	

Fastening Torque: 20Ncm (Narrow) - 30Ncm (Regular)

**NTA® T-BASE ABUTMENT**

NARROW REGULAR NON-HEX

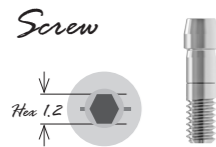
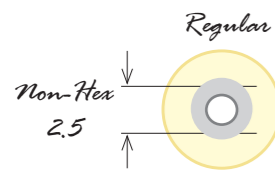
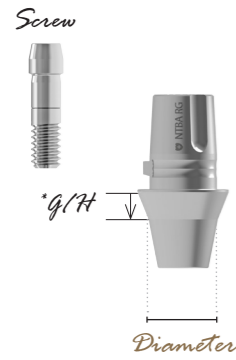

Fixture	Diameter	*G/H	Height	Product Code	Screw	
Regular	Ø 4.5	1	4.5	O-NTBA RG (4510 NH)	M 2.0 O-TBS 2008	
		2		O-NTBA RG (4520 NH)		
		3		O-NTBA RG (4530 NH)		
		4		O-NTBA RG (4540 NH)		
		5		O-NTBA RG (4550 NH)		
	Ø 5.5	1	O-NTBA RG (5510 NH)			
		2	O-NTBA RG (5520 NH)			
		3	O-NTBA RG (5530 NH)			
		4	O-NTBA RG (5540 NH)			
		5	O-NTBA RG (5550 NH)			
	Regular	Ø 4.5	1	5.5		O-NTBA RG (554510 NH)
			2			O-NTBA RG (554520 NH)
			3			O-NTBA RG (554530 NH)
			4			O-NTBA RG (554540 NH)
			5			O-NTBA RG (554550 NH)
Ø 5.5		1	O-NTBA RG (555510 NH)			
		2	O-NTBA RG (555520 NH)			
		3	O-NTBA RG (555530 NH)			
		4	O-NTBA RG (555540 NH)			
		5	O-NTBA RG (555550 NH)			
Regular		Ø 4.5	1	6.5	O-NTBA RG (654510 NH)	
			2		O-NTBA RG (654520 NH)	
			3		O-NTBA RG (654530 NH)	
			4		O-NTBA RG (654540 NH)	
			5		O-NTBA RG (654550 NH)	
	Ø 5.5	1	O-NTBA RG (655510 NH)			
		2	O-NTBA RG (655520 NH)			
		3	O-NTBA RG (655530 NH)			
		4	O-NTBA RG (655540 NH)			
		5	O-NTBA RG (655550 NH)			

Fastening Torque: 20Ncm (Narrow) - 30Ncm (Regular)

**NTA® T-BASE ANGLED ABUTMENT**

NARROW REGULAR HEX

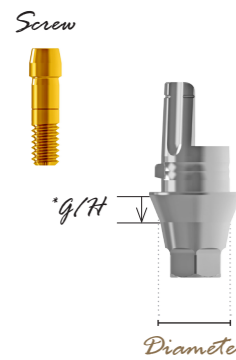

Fixture	Diameter	*G/H	Product Code	Screw
Narrow	Ø 4.5	1	O-NTBAA NR (4510 H)	O-TBS 1608
		2	O-NTBAA NR (4520 H)	O-TBS 1609
		3	O-NTBAA NR (4530 H)	O-TBS 1610
	Ø 5.5	1	O-NTBAA NR (5510 H)	O-TBS 1608
		2	O-NTBAA NR (5520 H)	O-TBS 1609
		3	O-NTBAA NR (5530 H)	O-TBS 1610
Regular	Ø 4.5	1	O-NTBAA RG (4510 H)	O-TBS 2008
		2	O-NTBAA RG (4520 H)	O-TBS 2009
		3	O-NTBAA RG (4530 H)	O-TBS 2010
	Ø 5.5	1	O-NTBAA RG (5510 H)	O-TBS 2008
		2	O-NTBAA RG (5520 H)	O-TBS 2009
		3	O-NTBAA RG (5530 H)	O-TBS 2010

Fastening Torque: 20Ncm (Narrow) - 30Ncm (Regular)

**NTA® T-BASE ANGLED ABUTMENT**

NARROW REGULAR NON-HEX

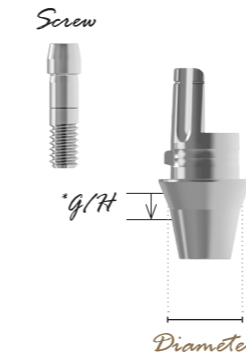

Fixture	Diameter	*G/H	Product Code	Screw
Narrow	Ø 4.5	1	O-NTBAA NR (4510 NH)	O-TBS 1608
		2	O-NTBAA NR (4520 NH)	O-TBS 1609
		3	O-NTBAA NR (4530 NH)	O-TBS 1610
	Ø 5.5	1	O-NTBAA NR (5510 NH)	O-TBS 1608
		2	O-NTBAA NR (5520 NH)	O-TBS 1609
		3	O-NTBAA NR (5530 NH)	O-TBS 1610
Regular	Ø 4.5	1	O-NTBAA RG (4510 NH)	O-TBS 2008
		2	O-NTBAA RG (4520 NH)	O-TBS 2009
		3	O-NTBAA RG (4530 NH)	O-TBS 2010
	Ø 5.5	1	O-NTBAA RG (5510 NH)	O-TBS 2008
		2	O-NTBAA RG (5520 NH)	O-TBS 2009
		3	O-NTBAA RG (5530 NH)	O-TBS 2010

Fastening Torque: 20Ncm (Narrow) - 30Ncm (Regular)

**T-Base Angled Outer Driver**

Height	Product Code
15	O-NTBAAOD



**NTA® BALL ABUTMENT**

NARROW REGULAR

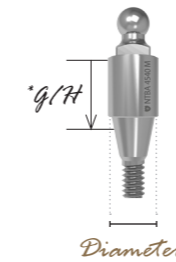

Fixture	Diameter	*G/H	Product Code
Narrow	Ø 4.5	1	O-NTBA 4510 M
		2	O-NTBA 4520 M
		3	O-NTBA 4530 M
		4	O-NTBA 4540 M
		5	O-NTBA 4550 M
		6	O-NTBA 4560 M
Regular	Ø 4.5	1	O-NTBA 4510
		2	O-NTBA 4520
		3	O-NTBA 4530
		4	O-NTBA 4540
		5	O-NTBA 4550
		6	O-NTBA 4560

Abutments for removable over-dentures.  
Fastening Torque: 20Ncm (Narrow) - 30Ncm (Regular)

**Ball Abutment Lab Fixture Analog**

Diameter	Height	Product Code
Ø 3.5	12	O-BALFA 3512



**Ball Abutment Outer Driver**

Height	Product Code
12	O-NTBAD



**Ball Abutment Retainer + O-Ring**

Retainer	O-Ring
O-NTBA	O-NTBAO



**NTA® N-LOC ABUTMENT**

NARROW REGULAR



Fixture	Diameter	*G/H	Product Code	Screw
Narrow	Ø 4.0	1	O-NT 401 N	M 1.6 O-LCS 1608
		2	O-NT 402 N	
		3	O-NT 403 N	
		4	O-NT 404 N	
		5	O-NT 405 N	
		6	O-NT 406 N	
Regular	Ø 4.0	1	O-NT 401 R	M 2.0 O-LCS 2008
		2	O-NT 402 R	
		3	O-NT 403 R	
		4	O-NT 404 R	
		5	O-NT 405 R	
		6	O-NT 406 R	

Fixture	Diameter	*G/H	Angle	Product Code
Narrow	Ø 4.5	1.5	15°	O-NT 41515 N
		3.0		O-NT 40315 N
Regular	Ø 4.5	1.5	15°	O-NT 41515 R
		3.0		O-NT 40315 R

✓ Pick-up type ( to be used with a custom tray ).



**N-Loc Lab Fixture Analog**

Diameter	Height	Product Code
Ø 4.0	10	O-LOCAD

**N-Loc Outer Driver**

Height	Product Code
11	O-LOCOD



**NTA® TRANSFER IMPRESSION COPING**

NARROW REGULAR

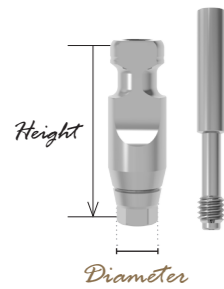

Fixture	Diameter	Height	Product Code	Pin
Narrow	Ø 4.0	11 (Short)	O-TIC 4011 M	O-TICP 1617
		14 (Long)	O-TIC 4014 M	O-TICP 1620
	Ø 5.0	11 (Short)	O-TIC 5011 M	O-TICP 1617
		14 (Long)	O-TIC 5014 M	O-TICP 1620
Regular	Ø 4.0	11 (Short)	O-TIC 4011 S	O-TICP 2017
		14 (Long)	O-TIC 4014 S	O-TICP 2020
	Ø 5.0	11 (Short)	O-TIC 5011 S	O-TICP 2017
		14 (Long)	O-TIC 5014 S	O-TICP 2020
	Ø 6.0	11 (Short)	O-TIC 6011 S	O-TICP 2017
		14 (Long)	O-TIC 6014 S	O-TICP 2020

✓ Impression coping for close tray.  
 ✓ Packing Unit: Impression coping + guide pin.  
 ✓ Hex type.  
 ✓ Available in short and long sizes.

**NTA® PICK-UP IMPRESSION COPING**

NARROW REGULAR HEX

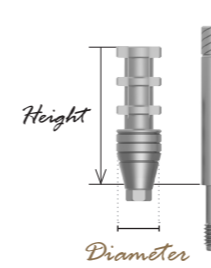

Fixture	Diameter	Height	Product Code	Pin
Narrow	Ø 4.5	10 (Short)	O-PIC 3410 MH	O-PICP 1613
		13 (Long)	O-PIC 3413 MH	O-PICP 1617
Regular	Ø 4.5	10 (Short)	O-PIC 4810 SH	O-PICP 2013
		13 (Long)	O-PIC 4813 SH	O-PICP 2017
	Ø 5.5	10 (Short)	O-PIC 5810 SH	O-PICP 2013

✓ Impression coping for custom tray (to be used with hex abutments).  
 ✓ Available in short and long sizes.

**NTA® PICK-UP IMPRESSION COPING**

NARROW REGULAR NON-HEX

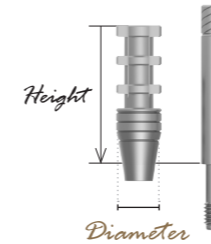

Fixture	Diameter	Height	Product Code	Pin
Narrow	Ø 4.5	10 (Short)	O-PIC 3410 MNH	O-PICP 1613
		13 (Long)	O-PIC 3413 MNH	O-PICP 1617
Regular	Ø 4.5	10 (Short)	O-PIC 4810 SNH	O-PICP 2013
		13 (Long)	O-PIC 4813 SNH	O-PICP 2017
	Ø 5.5	10 (Short)	O-PIC 5810 SNH	O-PICP 2013

✓ Impression coping for custom tray (to be used with non-hex abutments).  
 ✓ Available in short and long sizes.

**NTA® LAB FIXTURE ANALOG**

NARROW REGULAR

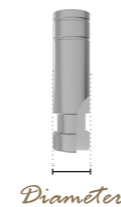

Fixture	Diameter	Product Code
Narrow	Ø 3.4	O-LFA 3412 M
Regular	Ø 3.7, Ø 4.2, Ø 4.6, Ø 5.1, Ø 6.0	O-LFA 4012

✓ Fixture analogs for the lab (to be used with appropriate abutments).

**NTA® SOLID LAB ANALOG**

NARROW REGULAR

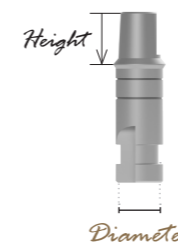

Diameter	Height	Product Code	Diameter	Height	Product Code	Diameter	Height	Product Code
Ø 4.5	4	O-SLA 4504	Ø 5.5	4	O-SLA 5504	Ø 6.5	4	O-SLA 6504
	5.5	O-SLA 4505		5.5	O-SLA 5505		5.5	O-SLA 6505
	7	O-SLA 4507		7	O-SLA 5507		7	O-SLA 6507

✓ Abutment analog (to be used with abutment level impression technique).

**NTA® IMPRESSION PLASTIC COPING**

NARROW REGULAR



Diameter	Product Code
Ø 4.15	O-IPC 4515
Ø 4.5	O-IPC 4510
Ø 5.5	O-IPC 5510
Ø 6.5	O-IPC 6510

✓ To be used both with cemented and solid abutments.

-INNOVATION-

# DIGITAL TECHNOLOGY



*Instant solution for patients!*

RESTORATION - IMPLANT - ORTHODONTICS

DECREASE THE OPERATION TIME!...

Thanks to the real-time display of scan data, dentists can analyze the data simultaneously. The scan head supports multi-mode disinfection.

*Gyroscope Technology!*

MOVE FREELY WITH A DOUBLE TAP!...

#### TRADITIONAL IMPRESSION METHODS

The preparation time is long,  
The use of foreign body generally disturbs the patient,  
Not comfortable,  
Taking a long time to prepare the prosthesis,  
Single, fixed pattern data; inconvenient for communication between doctor, technician and patient.

#### USING INTRAORAL SCANNER

Preparation time is shorter and more comfortable,  
The discomfort of the use of foreign body is minimized,  
Prosthesis waiting time is much shorter,  
The color data in the mouth can be displayed immediately, suitable for communication between doctors, technicians and patients.

#### No need to spray powder

Reduce the complexity of clinical operation.  
Simplify scanning process and save acquisition time.  
Improve patient comfort.

#### Color scanning

Real response to the actual situation of the patient's mouth.  
Easy to distinguish hard and soft tissue.

#### Endoscope function

During the scanning process, the patient's oral condition can be observed and photographed. Convenient communication between doctors and patients.

Whole mouth scanning time is less than 5 minutes, saving more time than traditional impressions.

#### GREAT DEPTH OF FIELD

Provides 15 mm depth of field to ensure data integrity.

#### BUILT-IN ANTI-FOG FUNCTION

The scanning head has built-in automatic heating and anti-fogging function. It provides a guarantee of the integrity of the data collected at once.



*A modern touch to digital dentistry!*



Material: Titanium Alloy (Ti-6Al-4VASTMF136)



*Pre-mill abutment*

Fixture	Diameter	Height	Product Code
Narrow	Ø 10	20	O-NTPAN 1020 H
Regular	Ø 10	20	O-NTPAR 1020 H

We are developing newest digital solutions to be able to provide more accurate and better options for our patients. We are providing a range of different products depending on the CAD system which is going to be applied.

Narrow  
O-LFA-D 3412 M



Regular  
O-LFA-D 4012



Multi  
O-MELA-D 300



O-MSB-S - Narrow Short



O-MSB-L - Narrow Long



O-RSB - Regular



O-RSB-L - Regular Long



O-MSB S010 H  
O-MSB 1010 H  
Multi Scan Body



O-MSB S007 NH  
O-MSB 1010 NH  
Multi Angled Scan Body



*Digital Analog*

*Scan Body*

For 3D printing model applications:

Applying customized implant and related treatments can be possible by using patients' periodontal information. To be able to provide our patients the best and easiest treatment we commit our state of the art digital equipments. We pledge our digital library to restore your smile.

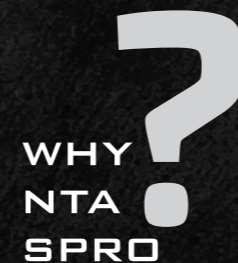

WWW.NTASPROSCANNER.COM



#### Wide clinical applications;

It can be used in dental restoration, implant and orthodontics.

#### CLOUD STORAGE

It can store data in the cloud for doctors to communicate and develop solutions in the cloud.

You can access all information by scanning the QR code below with your Smartphone / Tablet



GUIDE FOR IMPLANT SYSTEM

# Guide SURGICAL!

No Pain, Easy and Comfortable Surgery

No Pain, Easy and Comfortable Surgery

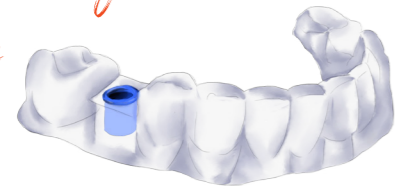

## ADVANTAGES GUIDE FOR IMPLANT SYSTEM

- 1 Safe and Accurate and Precise**  
Guide is produced according to condition of patient and makes surgery precise and safe.
- 2 No pain, Less Edema, Less Bleeding and Simple Procedure**  
Comparing to conventional implant surgery, Guide provides faster recovery and surgery without pain because there is no need to open flap and no need stitches.
- 3 Flapless and More Comfortable and Easier and Time-saving**  
No need stitches thanks to flapless surgery and lower chances to have injuries on gum. Guide reduces treatment time and makes surgeries much easier and more comfortable.
- 4 Chance to Apply Immediate Loading**  
No need to wait preparation of prosthesis. Guide provides immediate loading.



One sleeve for all drills



### GUIDE SLEEVE

Code: O-NT GS 35

FOR DRILL  
Code: O-NT GS 80



### SURGICAL GUIDE What is Surgical Guide?

In case of lack of one or more than one tooth, guide provides implant surgery without opening flap and is produced according to surgery area.



### Steps of Guide Surgery ;

Firstly, CT scan data and Oral scan data are provided and are transferred to 3D programmes. Thickness of bone is determined during implant planning with 3D programmes. Dental implants are placed into missing teeth and positions of implants is checked virtually at patient mouth before surgery.

After that guide is produced with 3D printers based on positions of implants designed virtually.

### 3D CT Scan ;

Decision of implant placing is made based on CT scan data of patient. If implant placement is applicable, CT scan data and oral scan data are used for implant planning with 3D programmes.

### Implant Planning ;

CT scan data, Oral scan data are provided firstly and transferred to 3D programmes. Thickness of bone is determined during implant planning by using 3D programmes. Dental implants are placed into missing teeth and positions of implants is checked virtually at patient mouth before surgery. After that guide is produced with 3D printers based on positions of implants designed virtually.

### Surgery ;

After putting surgical guide at patient mouth, implant placement areas are marked on gum. Holes that implants will be placed are prepared by drilling bone through the holes located on guide. After making ready gum for surgery, implants are placed into holes. Process is finalized by placing healing abutments or cover screws.

## NTA® SURGICAL GUIDE KIT



Code: NTA-0-00-06  
Nta Implant

### TORQUE RATCHET

Code: NTA-0-01-01



### GUIDE - POINT DRILL Ø2.2

Code: NTA-0-01-06



### GUIDE - POINT DRILL Ø5.2

Code: NTA-0-02-06



### TISSUE PUNCH DRILL Ø4.5

Code: NTA-0-03-06



### GUIDE - STRAIGHT TWIST DRILL

Code: NTA-0-29-06 L:5  
Code: NTA-0-30-06 L:7.5  
Code: NTA-0-31-06 L:8.5  
Code: NTA-0-32-06 L:10.0  
Code: NTA-0-33-06 L:11.5  
Code: NTA-0-34-06 L:13.0  
Code: NTA-0-65-06 L:15.0



### GUIDE - ANCHOR SCREW

Code: NTA-0-04-06



### GUIDE - CORTICAL DRILL

Code: NTA-0-05-06 Ø4.0  
Code: NTA-0-06-06 Ø4.5  
Code: NTA-0-07-06 Ø5.0



### GUIDE - VERTICAL ANCHOR

Code: NTA-0-08-06 0mm  
Code: NTA-0-09-06 2mm  
Code: NTA-0-10-06 4mm



### GUIDE - STRAIGHT TWIST DRILL

Code: NTA-0-35-06 L:5  
Code: NTA-0-36-06 L:7.5  
Code: NTA-0-37-06 L:8.5  
Code: NTA-0-38-06 L:10.0  
Code: NTA-0-39-06 L:11.5  
Code: NTA-0-40-06 L:13.0  
Code: NTA-0-66-06 L:15.0



### GUIDE - ANCHOR DRILL Ø1.35

Code: NTA-0-11-06



### GUIDE - ANCHOR DRIVER

Code: NTA-0-12-06  
HANDPIECE



### GUIDE - ANCHOR DRIVER

Code: NTA-0-13-06  
MANUAL



### GUIDE - STRAIGHT TWIST DRILL

Code: NTA-0-41-06 L:5  
Code: NTA-0-42-06 L:7.5  
Code: NTA-0-43-06 L:8.5  
Code: NTA-0-44-06 L:10.0  
Code: NTA-0-45-06 L:11.5  
Code: NTA-0-46-06 L:13.0  
Code: NTA-0-67-06 L:15.0



### GUIDE - TUBE (HANDLE GUIDE) Ø2.2

Code: NTA-0-14-06



### GUIDE - BONE ROUND DRILL

Code: NTA-0-15-06 Ø3.5  
Code: NTA-0-16-06 Ø5.0



### HANDPIECE GUIDE - FIXTURE DRIVER

Narrow  
Code: NTA-0-17-06 / SHORT  
Code: NTA-0-18-06 / LONG

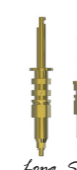

### GUIDE - STRAIGHT TWIST DRILL

Code: NTA-0-47-06 L:5  
Code: NTA-0-48-06 L:7.5  
Code: NTA-0-49-06 L:8.5  
Code: NTA-0-50-06 L:10.0  
Code: NTA-0-51-06 L:11.5  
Code: NTA-0-52-06 L:13.0  
Code: NTA-0-68-06 L:15.0



### HANDPIECE GUIDE - FIXTURE DRIVER

Regular  
Code: NTA-0-19-06 / SHORT  
Code: NTA-0-20-06 / LONG



### MANUAL GUIDE - FIXTURE DRIVER

Narrow  
Code: NTA-0-21-06 / SHORT  
Code: NTA-0-22-06 / LONG



### MANUAL GUIDE - FIXTURE DRIVER

Regular  
Code: NTA-0-23-06 / SHORT  
Code: NTA-0-24-06 / LONG



### GUIDE - STRAIGHT TWIST DRILL

Code: NTA-0-53-06 L:5  
Code: NTA-0-54-06 L:7.5  
Code: NTA-0-55-06 L:8.5  
Code: NTA-0-56-06 L:10.0  
Code: NTA-0-57-06 L:11.5  
Code: NTA-0-58-06 L:13.0  
Code: NTA-0-69-06 L:15.0



### HANDPIECE GUIDE - SCREW DRIVER

Code: NTA-0-25-06  
SHORT



### MANUAL GUIDE - SCREW DRIVER

Code: NTA-0-26-06  
SHORT



### GUIDE - DRILL EXT.

Code: NTA-0-11-01



### GUIDE - STRAIGHT TWIST DRILL

Code: NTA-0-59-06 L:5  
Code: NTA-0-60-06 L:7.5  
Code: NTA-0-61-06 L:8.5  
Code: NTA-0-62-06 L:10.0  
Code: NTA-0-63-06 L:11.5  
Code: NTA-0-64-06 L:13.0  
Code: NTA-0-70-06 L:15.0



Code: **NTA-0-00-01**  
**+ SURGICAL KIT**  
*Nta Implant*



**+ TORQUE RATCHET**  
 Code: **NTA-0-01-01**



**+ POINT DRILL Ø1.5**  
 Code: **NTA-0-9-01**



**+ GUIDE DRILL Ø2.0**  
 Code: **NTA-0-10-01**



**+ DRILL EXTENSION**  
 Code: **NTA-0-11-01**



**+ PARALLEL PIN**  
 Code: **NTA-0-12-01**



**+ TAPERED DRILL Ø2.3 / Ø2.9**  
 Code: **NTA-0-13-01 (T)**



**+ MANUAL SCREW DRIVER - SHORT**  
 Code: **NTA-0-14-01**



**+ MANUAL SCREW DRIVER - LONG**  
 Code: **NTA-0-14-02**



**+ HANDPIECE FIXTURE DRIVER - REGULAR**  
 Code: **NTA-0-15-01-S**  
 Code: **NTA-0-15-01-L**



**+ MANUAL FIXTURE DRIVER - REGULAR**  
 Code: **NTA-0-15-02-S**  
 Code: **NTA-0-15-02-L**



**+ HANDPIECE FIXTURE DRIVER - NARROW**  
 Code: **NTA-0-16-01-S**  
 Code: **NTA-0-16-01-L**



**+ MANUAL FIXTURE DRIVER - NARROW**  
 Code: **NTA-0-16-02-S**  
 Code: **NTA-0-16-02-L**



**+ FIXTURE PIN**  
 Code: **NTA-0-17-01 (Nr)**  
 Code: **NTA-0-17-02 (Rg)**



**+ STRAIGHT TWIST DRILLS**  
 Code: **NTA-0-2-01 / Ø 2.0x6.5**  
 Code: **NTA-0-2-02 / Ø 2.0x7.5**  
 Code: **NTA-0-2-03 / Ø 2.0x8.5**  
 Code: **NTA-0-2-04 / Ø 2.0x10**  
 Code: **NTA-0-2-05 / Ø 2.0x11.5**  
 Code: **NTA-0-2-06 / Ø 2.0x13**



**+ FINAL DRILLS Ø3.4 / NARROW**  
 Code: **NTA-0-3-01 (T) / Ø 3.4x7.5**  
 Code: **NTA-0-3-02 (T) / Ø 3.4x8.5**  
 Code: **NTA-0-3-03 (T) / Ø 3.4x10**  
 Code: **NTA-0-3-04 (T) / Ø 3.4x11.5**  
 Code: **NTA-0-3-05 (T) / Ø 3.4x13**



**+ FINAL DRILLS Ø3.7 / REGULAR**  
 Code: **NTA-0-4-01 (T) / Ø 3.7x7.5**  
 Code: **NTA-0-4-02 (T) / Ø 3.7x8.5**  
 Code: **NTA-0-4-03 (T) / Ø 3.7x10**  
 Code: **NTA-0-4-04 (T) / Ø 3.7x11.5**  
 Code: **NTA-0-4-05 (T) / Ø 3.7x13**



**+ FINAL DRILLS Ø4.2 / REGULAR**  
 Code: **NTA-0-5-01 (T) / Ø 4.2x7.5**  
 Code: **NTA-0-5-02 (T) / Ø 4.2x8.5**  
 Code: **NTA-0-5-03 (T) / Ø 4.2x10**  
 Code: **NTA-0-5-04 (T) / Ø 4.2x11.5**  
 Code: **NTA-0-5-05 (T) / Ø 4.2x13**



**+ FINAL DRILLS Ø4.6 / REGULAR**  
 Code: **NTA-0-6-01 (T) / Ø 4.6x7.5**  
 Code: **NTA-0-6-02 (T) / Ø 4.6x8.5**  
 Code: **NTA-0-6-03 (T) / Ø 4.6x10**  
 Code: **NTA-0-6-04 (T) / Ø 4.6x11.5**  
 Code: **NTA-0-6-05 (T) / Ø 4.6x13**



**+ FINAL DRILL Ø5.1 / REGULAR**  
 Code: **NTA-0-7-01 (T) / Ø 5.1x13**



**+ FINAL DRILL Ø6.0 / REGULAR**  
 Code: **NTA-0-8-01 (T) / Ø 6.0x13**



**+ DEPTH GAUGE**  
 Code: **NTA-0-18-01**



*Point Drill*

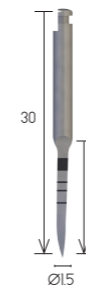

*Guide Drill*

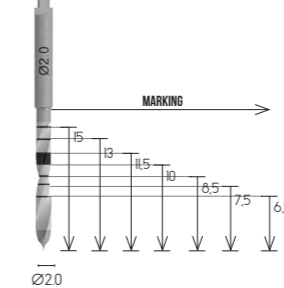

*Straight Twist Drill*

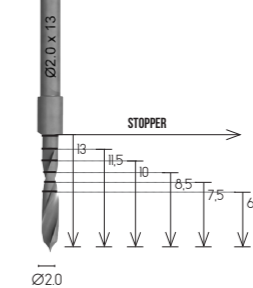

*Tapered Drill*

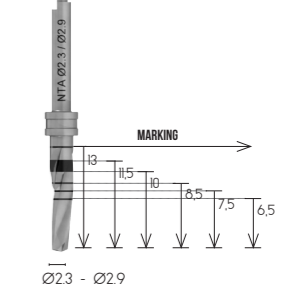

*Ø 3.4 Narrow Final Drill*

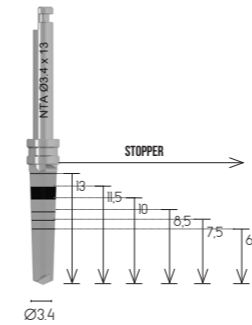

*Ø 3.7 Regular Final Drill*

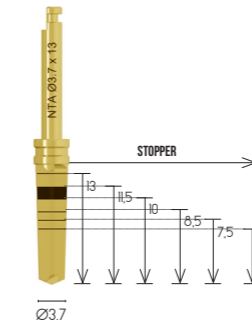

*Ø 4.2 Regular Final Drill*

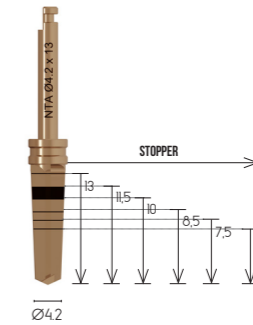

*Ø 4.6 Regular Final Drill*

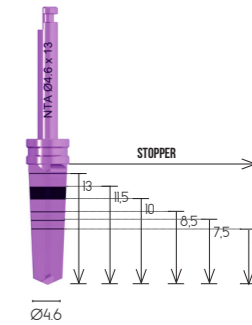

*Ø 5.1 Regular Final Drill*

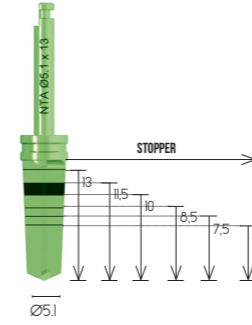

*Ø 6.0 Regular Final Drill*

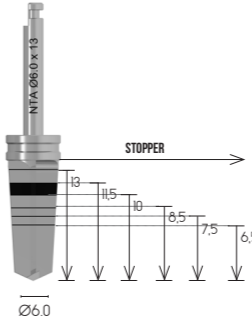

*Parallel Pin*



*Fixture Pin*



*Drill Extension*



*Fixture Driver Narrow*

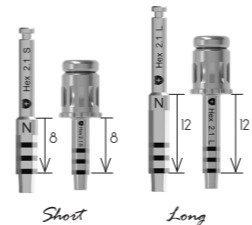

*Fixture Driver Regular*

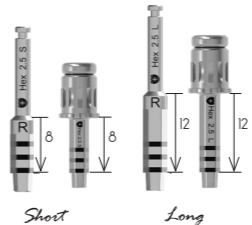

*1,2 Screw Driver*

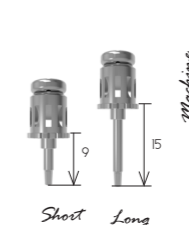

*Ball Driver*



*Multi Driver*



*Octa Driver*



NTA SURGICAL KIT PROTOCOL

1200rpm 1000rpm 800rpm 800rpm 800rpm 800rpm

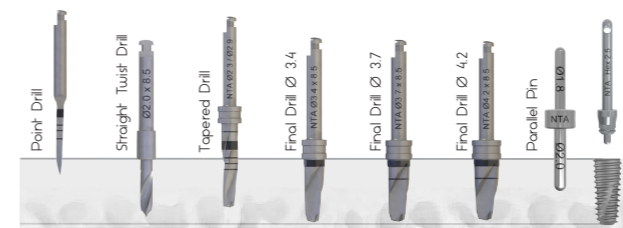

MEDIUM & HARD (D1 + D2+ D3)

1200rpm 1000rpm 800rpm 800rpm 800rpm

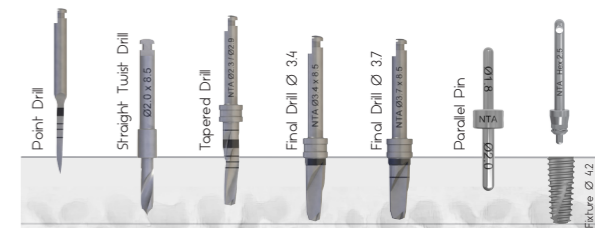

SOFT (D4)

**+ NTA® IMPLANT MINI SURGICAL KIT ( NON-STOPER )**

Code: **NTA-0-00-08**  
Nta Implant



**+ POINT DRILL Ø1.5**  
Code: **NTA-0-9-01**



**+ TAPERED DRILL Ø2.3 / Ø2.9**  
Code: **NTA-0-13-01-T**



**+ DRILL EXTENSION**  
Code: **NTA-0-11-01**



**+ PARALLEL PIN**  
Code: **NTA-0-12-01**



**+ MANUAL SCREW DRIVER - LONG**  
Code: **NTA-0-14-02**



**+ HANDPIECE FIXTURE DRIVER - NARROW**  
Code: **NTA-0-16-01-S**



**+ DEPTH GAUGE**  
Code: **NTA-0-18-01**



**+ HANDPIECE FIXTURE DRIVER - REGULAR**  
Code: **NTA-0-15-01-S**



**+ MANUAL FIXTURE DRIVER - REGULAR**  
Code: **NTA-0-15-02-L**



**+ MANUAL FIXTURE DRIVER - NARROW**  
Code: **NTA-0-16-02-L**



**+ FINAL DRILLS Ø3.4 / NARROW**  
Code: **NTA-0-3-06-T**  
Ø 3.4x15



**+ FINAL DRILLS Ø3.7 / REGULAR**  
Code: **NTA-0-4-06-T**  
Ø 3.7x15



**+ FINAL DRILLS Ø4.2 / REGULAR**  
Code: **NTA-0-5-06-T**  
Ø 4.2x15



**+ FINAL DRILLS Ø4.6 / REGULAR**  
Code: **NTA-0-6-06-T**  
Ø 4.6x15



**+ FINAL DRILL Ø5.1 / REGULAR**  
Code: **NTA-0-7-02-T**  
Ø 5.1x15



**+ FINAL DRILL Ø6.0 / REGULAR**  
Code: **NTA-0-8-02-T**  
Ø 6.0x15



**+ TORQUE RATCHET**  
Code: **NTA-0-01-01**



**+ NTA® ABUTMENT SCREW REMOVER KIT**

Code: **NTA-0-00-02**  
Nta Implant



**+ NON-TORQUE RATCHET**  
Code: **NTA-0-01-02**



**+ GUIDE DRIVER - HEX**  
Code: **NTA-SRK-001**



**+ ADAPTER**  
Code: **NTA-SRK-006**



**+ GUIDE DRIVER - NON-HEX**  
Code: **NTA-SRK-002**



**+ DRILL Ø1.4 (L)**  
Code: **NTA-SRK-004**



**+ DRILL Ø1.2**  
Code: **NTA-SRK-003**



**+ DRILL Ø1.4 (S)**  
Code: **NTA-SRK-005**



**+ NTA® PROSTHETIC KIT**

Code: **NTA-0-00-03**  
Nta Implant



**+ MANUAL SCREW DRIVER - SHORT**  
Code: **NTA-0-14-01**



**+ MANUAL SCREW DRIVER - LONG**  
Code: **NTA-0-14-02**



**+ MULTI - OUTER DRIVER**  
Code: **O-MAOD**



**+ BALL - OUTER DRIVER**  
Code: **O-NTBAD**



**+ OCTA - OUTER DRIVER**  
Code: **O-OAOD**



**+ N-LOC - OUTER DRIVER**  
Code: **O-LOCOD**



**+ TORQUE RATCHET**  
Code: **NTA-0-01-01**



**+ MACHINE DRIVER**  
Code: **NTA-PK-001**



**NTA® MULTI PROSTHETIC PLANNING KIT**



(PLANNER)  
(ALL ON FOUR SYSTEM)  
**+** MULTI ABUTMENT

Code: **NTA-0-00-05**  
*Nta Implant*

Code: P-NTMA(N) 5010	Diameter: Ø 4.8	G/H: 1	Code: P-NTMA(R) 5010	Diameter: Ø 4.8	G/H: 1
Code: P-NTMA(N) 5020	Diameter: Ø 4.8	G/H: 2	Code: P-NTMA(R) 5020	Diameter: Ø 4.8	G/H: 2
Code: P-NTMA(N) 5030	Diameter: Ø 4.8	G/H: 3	Code: P-NTMA(R) 5030	Diameter: Ø 4.8	G/H: 3
Code: P-NTMA(N) 5040	Diameter: Ø 4.8	G/H: 4	Code: P-NTMA(R) 5040	Diameter: Ø 4.8	G/H: 4



(PLANNER)  
(ALL ON FOUR SYSTEM)  
**+** MULTI ANGLED ABUTMENT

Code: P-NT17MAN 4820	Diameter: Ø 4.8	G/H: 2	Angle: 17°
Code: P-NT17MAN 4830	Diameter: Ø 4.8	G/H: 3	Angle: 17°
Code: P-NT17MAN 4840	Diameter: Ø 4.8	G/H: 4	Angle: 17°
Code: P-NT30MAN 4830	Diameter: Ø 4.8	G/H: 3	Angle: 30°
Code: P-NT30MAN 4840	Diameter: Ø 4.8	G/H: 4	Angle: 30°
Code: P-NT30MAN 4850	Diameter: Ø 4.8	G/H: 5	Angle: 30°
Code: P-NT17MAR 4820	Diameter: Ø 4.8	G/H: 2	Angle: 17°
Code: P-NT17MAR 4830	Diameter: Ø 4.8	G/H: 3	Angle: 17°
Code: P-NT17MAR 4840	Diameter: Ø 4.8	G/H: 4	Angle: 17°
Code: P-NT30MAR 4830	Diameter: Ø 4.8	G/H: 3	Angle: 30°
Code: P-NT30MAR 4840	Diameter: Ø 4.8	G/H: 4	Angle: 30°
Code: P-NT30MAR 4850	Diameter: Ø 4.8	G/H: 5	Angle: 30°

**NTA® BONE EXPANDER**



(PLANNER)  
**+** CEMENTED ABUTMENT

Code: **NTA-0-00-07**  
*Nta Implant*

<b>+</b> RATCHET ADAPTER Code: NTA-0-10-07	<b>+</b> HANDPIECE ADAPTER Code: NTA-0-11-07
<b>+</b> EXPANDER Ø2.6 Code: NTA-0-04-07	<b>+</b> EXPANDER Ø3.0 Code: NTA-0-05-07
<b>+</b> CREST TRIMMER Ø5.0 Code: NTA-0-01-07	<b>+</b> EXPANDER Ø3.4 Code: NTA-0-06-07
<b>+</b> SAW (Ø10 THICKNESS: 0.3MM) Code: NTA-0-02-07	<b>+</b> EXPANDER Ø3.8 Code: NTA-0-07-07
<b>+</b> DRILL Ø1.8 Code: NTA-0-03-07	<b>+</b> EXPANDER Ø4.3 Code: NTA-0-08-07
<b>+</b> RATCHET Code: NTA-0-09-07	<b>+</b> HAND ADAPTER Code: NTA-0-12-07
<b>+</b> COMPLEMENT KIT 02 Code: NTA-0-14-07	<b>+</b> COMPLEMENT KIT 01 Code: NTA-0-13-07

**NTA® PROSTHETIC PLANNING KIT**

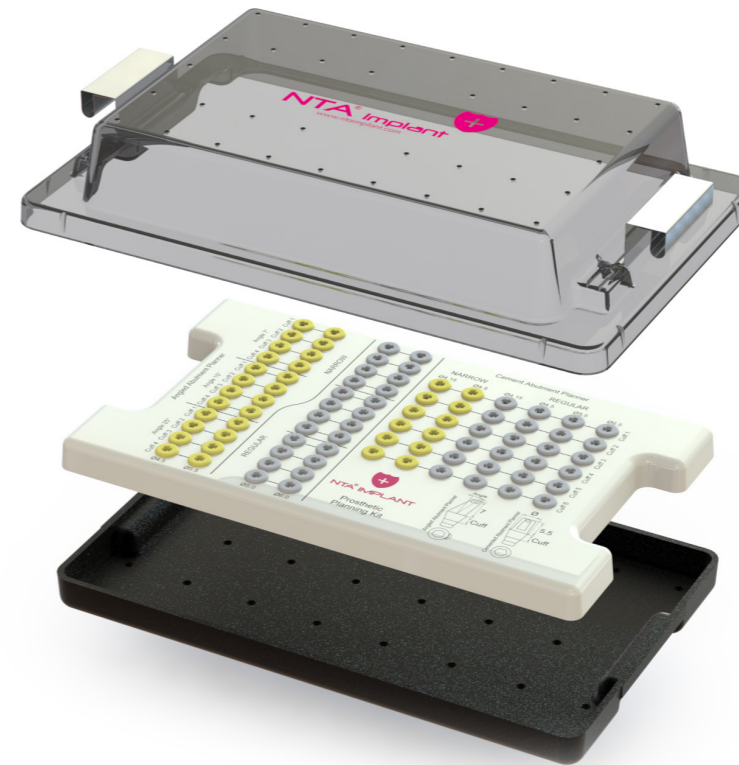

(PLANNER)  
**+** ANGLED ABUTMENT

Code: **NTA-0-00-04**  
*Nta Implant*

Code: P-NTAA 45107 MH	Diameter: Ø 4.5	G/H: 1	Angle: 7°
Code: P-NTAA 45207 MH	Diameter: Ø 4.5	G/H: 2	Angle: 7°
Code: P-NTAA 45307 MH	Diameter: Ø 4.5	G/H: 3	Angle: 7°
Code: P-NTAA 45407 MH	Diameter: Ø 4.5	G/H: 4	Angle: 7°
Code: P-NTAA 45115 MH	Diameter: Ø 4.5	G/H: 1	Angle: 15°
Code: P-NTAA 45215 MH	Diameter: Ø 4.5	G/H: 2	Angle: 15°
Code: P-NTAA 45315 MH	Diameter: Ø 4.5	G/H: 3	Angle: 15°
Code: P-NTAA 45415 MH	Diameter: Ø 4.5	G/H: 4	Angle: 15°
Code: P-NTAA 45125 MH	Diameter: Ø 4.5	G/H: 1	Angle: 25°
Code: P-NTAA 45225 MH	Diameter: Ø 4.5	G/H: 2	Angle: 25°
Code: P-NTAA 45325 MH	Diameter: Ø 4.5	G/H: 3	Angle: 25°
Code: P-NTAA 45425 MH	Diameter: Ø 4.5	G/H: 4	Angle: 25°
Code: P-NTAA 55107 MH	Diameter: Ø 5.5	G/H: 1	Angle: 7°
Code: P-NTAA 55207 MH	Diameter: Ø 5.5	G/H: 2	Angle: 7°
Code: P-NTAA 55307 MH	Diameter: Ø 5.5	G/H: 3	Angle: 7°
Code: P-NTAA 55407 MH	Diameter: Ø 5.5	G/H: 4	Angle: 7°
Code: P-NTAA 55115 MH	Diameter: Ø 5.5	G/H: 1	Angle: 15°
Code: P-NTAA 55215 MH	Diameter: Ø 5.5	G/H: 2	Angle: 15°
Code: P-NTAA 55315 MH	Diameter: Ø 5.5	G/H: 3	Angle: 15°
Code: P-NTAA 55415 MH	Diameter: Ø 5.5	G/H: 4	Angle: 15°
Code: P-NTAA 55125 MH	Diameter: Ø 5.5	G/H: 1	Angle: 25°
Code: P-NTAA 55225 MH	Diameter: Ø 5.5	G/H: 2	Angle: 25°
Code: P-NTAA 55325 MH	Diameter: Ø 5.5	G/H: 3	Angle: 25°
Code: P-NTAA 55425 MH	Diameter: Ø 5.5	G/H: 4	Angle: 25°
Code: P-NTAA 50107 SH	Diameter: Ø 5.0	G/H: 1	Angle: 7°
Code: P-NTAA 50207 SH	Diameter: Ø 5.0	G/H: 2	Angle: 7°
Code: P-NTAA 50307 SH	Diameter: Ø 5.0	G/H: 3	Angle: 7°
Code: P-NTAA 50407 SH	Diameter: Ø 5.0	G/H: 4	Angle: 7°
Code: P-NTAA 50115 SH	Diameter: Ø 5.0	G/H: 1	Angle: 15°
Code: P-NTAA 50215 SH	Diameter: Ø 5.0	G/H: 2	Angle: 15°
Code: P-NTAA 50315 SH	Diameter: Ø 5.0	G/H: 3	Angle: 15°
Code: P-NTAA 50415 SH	Diameter: Ø 5.0	G/H: 4	Angle: 15°
Code: P-NTAA 50125 SH	Diameter: Ø 5.0	G/H: 1	Angle: 25°
Code: P-NTAA 50225 SH	Diameter: Ø 5.0	G/H: 2	Angle: 25°
Code: P-NTAA 50325 SH	Diameter: Ø 5.0	G/H: 3	Angle: 25°
Code: P-NTAA 50425 SH	Diameter: Ø 5.0	G/H: 4	Angle: 25°
Code: P-NTAA 60107 SH	Diameter: Ø 6.0	G/H: 1	Angle: 7°
Code: P-NTAA 60207 SH	Diameter: Ø 6.0	G/H: 2	Angle: 7°
Code: P-NTAA 60307 SH	Diameter: Ø 6.0	G/H: 3	Angle: 7°
Code: P-NTAA 60407 SH	Diameter: Ø 6.0	G/H: 4	Angle: 7°
Code: P-NTAA 60115 SH	Diameter: Ø 6.0	G/H: 1	Angle: 15°
Code: P-NTAA 60215 SH	Diameter: Ø 6.0	G/H: 2	Angle: 15°
Code: P-NTAA 60315 SH	Diameter: Ø 6.0	G/H: 3	Angle: 15°
Code: P-NTAA 60415 SH	Diameter: Ø 6.0	G/H: 4	Angle: 15°
Code: P-NTAA 60125 SH	Diameter: Ø 6.0	G/H: 1	Angle: 25°
Code: P-NTAA 60225 SH	Diameter: Ø 6.0	G/H: 2	Angle: 25°
Code: P-NTAA 60325 SH	Diameter: Ø 6.0	G/H: 3	Angle: 25°
Code: P-NTAA 60425 SH	Diameter: Ø 6.0	G/H: 4	Angle: 25°

(PLANNER)  
**+** CEMENTED ABUTMENT

Code: P-NTCA 20515 H	Diameter: Ø 4.15	G/H: 1	Code: P-NTCA 45515 H	Diameter: Ø 4.5	G/H: 1
Code: P-NTCA 20525 H	Diameter: Ø 4.15	G/H: 2	Code: P-NTCA 45525 H	Diameter: Ø 4.5	G/H: 2
Code: P-NTCA 20535 H	Diameter: Ø 4.15	G/H: 3	Code: P-NTCA 45535 H	Diameter: Ø 4.5	G/H: 3
Code: P-NTCA 20545 H	Diameter: Ø 4.15	G/H: 4	Code: P-NTCA 45545 H	Diameter: Ø 4.5	G/H: 4
Code: P-NTCA 20555 H	Diameter: Ø 4.15	G/H: 5	Code: P-NTCA 45555 H	Diameter: Ø 4.5	G/H: 5
Code: P-NTCA 20565 H	Diameter: Ø 4.15	G/H: 6	Code: P-NTCA 45565 H	Diameter: Ø 4.5	G/H: 6
Code: P-NTCA 30515 H	Diameter: Ø 4.5	G/H: 1	Code: P-NTCA 55615 H	Diameter: Ø 5.5	G/H: 1
Code: P-NTCA 30525 H	Diameter: Ø 4.5	G/H: 2	Code: P-NTCA 55625 H	Diameter: Ø 5.5	G/H: 2
Code: P-NTCA 30535 H	Diameter: Ø 4.5	G/H: 3	Code: P-NTCA 55635 H	Diameter: Ø 5.5	G/H: 3
Code: P-NTCA 30545 H	Diameter: Ø 4.5	G/H: 4	Code: P-NTCA 55645 H	Diameter: Ø 5.5	G/H: 4
Code: P-NTCA 30555 H	Diameter: Ø 4.5	G/H: 5	Code: P-NTCA 55655 H	Diameter: Ø 5.5	G/H: 5
Code: P-NTCA 30565 H	Diameter: Ø 4.5	G/H: 6	Code: P-NTCA 55665 H	Diameter: Ø 5.5	G/H: 6
Code: P-NTCA 40515 H	Diameter: Ø 4.15	G/H: 1	Code: P-NTCA 65715 H	Diameter: Ø 6.5	G/H: 1
Code: P-NTCA 40525 H	Diameter: Ø 4.15	G/H: 2	Code: P-NTCA 65725 H	Diameter: Ø 6.5	G/H: 2
Code: P-NTCA 40535 H	Diameter: Ø 4.15	G/H: 3	Code: P-NTCA 65735 H	Diameter: Ø 6.5	G/H: 3
Code: P-NTCA 40545 H	Diameter: Ø 4.15	G/H: 4	Code: P-NTCA 65745 H	Diameter: Ø 6.5	G/H: 4
Code: P-NTCA 40555 H	Diameter: Ø 4.15	G/H: 5	Code: P-NTCA 65755 H	Diameter: Ø 6.5	G/H: 5
Code: P-NTCA 40565 H	Diameter: Ø 4.15	G/H: 6	Code: P-NTCA 65765 H	Diameter: Ø 6.5	G/H: 6

## Surgical Tool Maintenance Process



## Multi<sup>+</sup> Abutment!

All On Four System

*Ease of use*  
*Intelligent design*  
*Restorative flexibility*



*Multi Abutment*

## Ez Screw<sup>®</sup>

**EASY USE, STRONG CONNECTION!**

**FULLY DIGITAL**  
**NO BREAKAGE / LOOSENING**  
**EASY TO TORQUE**  
**CAN BE APPLIED DIRECTLY TO MUA**

There is no issue of screw loosening in multi-unit prostheses.  
It is ergonomic and eliminates the need for a multi cap or zircon ring.  
It can be easily torqued.  
There is no risk of breakage; it is durable due to its design and thickness.





 Pilatus Swiss Dental GmbH  
Dorfchärn • CH-6243 Egolzwil, Switzerland  
Tel: +41 41 982 07 07 Fax: +41 41 982 03 03  
info@pilatusswiss.ch • www.pilatusswiss.ch



NTA Implant Grup San. Ticaret A.Ş.  
Mehmetçik Mah. 1241 Sok. No:4 Antalya / Türkiye  
Tel: +90 444 9 431 Fax: +90 242 244 02 14  
info@ntaimplant.com • www.ntaimplant.com